

# **AIR AND RAIL COMPETITION AND COMPLEMENTARITY**

**Case study report**

**Report**

**August 2006**

**Prepared for:**

European Commission  
DG Energy and Transport

**Prepared by:**

Steer Davies Gleave  
28-32 Upper Ground  
London  
SE1 9PD

+44 (0)20 7919 8500  
[www.steerdaviesgleave.com](http://www.steerdaviesgleave.com)



<b>Contents</b>	<b>Page</b>
<b>1. INTRODUCTION</b>	<b>5</b>
Background	5
This report	5
<b>2. CASE STUDY SELECTION</b>	<b>6</b>
Outline	6
Criteria for route selection	6
Evaluation of proposed routes against criteria	8
Route selection	11
Change to route selection during the study	13
<b>3. LONDON - PARIS</b>	<b>14</b>
Introduction	14
Service provision	14
Market size and share	17
Access to the services	19
Airport connections	25
Fares	26
Service quality and on board services	28
Reliability	29
Taxes and subsidies	31
Future developments	32
Conclusions	32
<b>4. MADRID - BARCELONA</b>	<b>34</b>
Introduction	34
Journey times and frequencies	34
Market Share	38
Market characteristics	39
Prices and Revenues	41
Punctuality	44
Air-rail links	45
Service quality characteristics	45
Taxes, subsidies and regulatory limits	47
Future changes	48
Conclusions	50

<b>5. MADRID - SEVILLE</b>	<b>51</b>
Introduction	51
Journey times and frequencies	51
Market share	53
Access to Services	55
Prices and Revenues	55
Punctuality	58
Air-rail links	59
Service quality	59
Taxes, subsidies and regulatory limits	61
Future changes	62
Potential for low cost competition	62
Conclusions	63
<b>6. ROME – MILAN</b>	<b>64</b>
Introduction	64
Service provision	64
Market size and share	68
Other modes of transport	70
Access to the services	70
Airport connections	72
Fares	73
Service quality and on board services	75
Reliability	76
Taxes and subsidies	77
Future developments	78
Conclusions	79
<b>7. PARIS - MARSEILLE</b>	<b>81</b>
Introduction	81
Service provision	81
Market size and share	83
Access to the services	85
Fares	87
Service quality and on-board services	89
Air-rail connections	91

---

Taxes, subsidies and regulation	92
Future developments	93
Competition from low-cost airlines	94
Conclusions	95
<b>8. COLOGNE - FRANKFURT</b>	<b>96</b>
Introduction	96
Service provision	96
Market size and share	98
Access to the services	100
Airport connections	101
Fares and ticketing	103
Service quality and on board services	109
Reliability	110
Taxes, subsidies and regulatory limits	110
Potential for low cost competition	111
Future developments	111
Conclusions	112
<b>9. LONDON - EDINBURGH</b>	<b>114</b>
Introduction	114
Service provision	114
Service provision	115
Market size and share	117
Access to services	119
Airport connections	123
Fares	123
Reliability and punctuality	126
Service quality and on board services	128
Taxes and subsidies	129
Regulatory limits	129
Future changes	130
Conclusions	131
<b>10. LONDON-MANCHESTER</b>	<b>132</b>
Introduction	132
Service provision	132

Market size and share	135
Access to services	138
Air-rail connections	141
Fares and ticketing	141
Service quality and on-board services	143
Punctuality and reliability	144
Taxes, subsidies and regulatory limits	145
Future developments	146
Conclusions	146

## 1. INTRODUCTION

### Background

- 1.1 As part of our study into competition and complementarity of air and rail transport, we have undertaken case studies of eight European routes. The objective of the case studies was to understand the main factors driving the market share of rail operators, classic airlines and low cost airlines on each route.
- 1.2 The case studies were based on research from a number of (mostly public) sources. We also interviewed a number of operators, in order to obtain data where this was not available publicly, and to discuss the key factors which they believed influenced market share. We are very grateful to the following operators who have provided assistance with our research:
- **Rail operators:** RENFE, Trenitalia, Eurostar, Deutsche Bahn, Virgin Trains and GNER
  - **Airlines:** Iberia, Alitalia, Air One, Vueling, easyJet, Ryanair and Lufthansa
- 1.3 We also wish to express our thanks to the French civil aviation authority (DGAC) and rail infrastructure manager (RFF) for their assistance.

### This report

- 1.4 This report should be read as a supplement to the main report for the study, which includes a summary of the key conclusions from the case studies. It includes each case study and explains why we selected the routes that we did for the case studies.

## 2. CASE STUDY SELECTION

### Outline

- 2.1 This section describes why we selected the eight case studies that are set out in this document. The process that we followed is summarised in Figure 2.1 below. The Commission proposed an initial list of case studies which we evaluated in order to assess how well they enabled us to meet the various objectives for the study. We also evaluated some alternative routes, undertook a detailed discussion of the merits of different routes with the Commission, and agreed on a revised list of case studies. In one case, we subsequently found that it was not possible to complete a case study, due to the non co-operation of a key operator, and in this case we agreed on an alternative route with the Commission.

**FIGURE 2.1 PROCESS FOR CASE STUDY SELECTION**

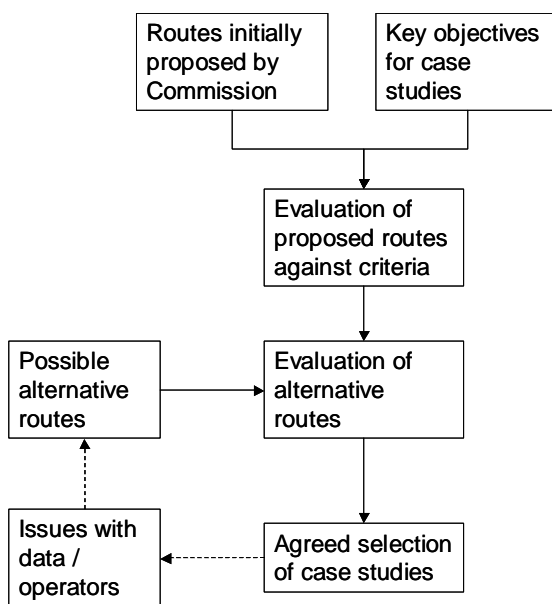

### Criteria for route selection

- 2.2 The key reason for selecting a route is that it can usefully contribute to the objectives of the study, the aspects of which relating to route selection were set out by the Commission, in the Terms of Reference, as follows:

*“For the European Commission to gain a better understanding of:*

- *What are the present terms of the market split between high speed trains, “classic” airlines and LC airlines services: role of prices, travel duration, frequency, other aspects of the service (including easiness of connection for travel continuation), marketing policy?*
- *What are the production costs of a seat-km?*
- *And what economically viable changes in the respective production processes and offers of the 3 types of operators, in the short and medium (5-10 years) term, could result in a lasting modification of the modal split model?”*



- 2.3 It was necessary for all routes studied to meet certain criteria, most importantly that services by all three types of transport (classic air, low cost air, and rail) should, at least in principle, be possible. So, for example, we did not evaluate a route such as London-Dublin, where surface travel is inherently unattractive due to the sea crossing, or a route such as Madrid-Córdoba, as, although the length of the route is appropriate for an air service, Córdoba has no airport.
- 2.4 In addition, in order to answer the questions set out in the Terms of Reference, it was necessary to have routes which fulfil a range of other criteria and have different characteristics. It was not possible (or desirable) for all routes to meet all of these criteria. An objective of the study will be to show the relative impacts of different characteristics against each criterion. These criteria are:
- **Presence of a fast direct passenger service:** All selected routes should have new high speed rail infrastructure, or a service which approximates high speed rail by having similar characteristics (high-speed, high-quality direct services). It is essential that all routes have a fast rail service, but not necessarily low-cost air, as the barriers to entry by low cost airlines are generally low, whereas the construction of a rail line is clearly an important investment decision, requiring substantial sunk costs and a planning and construction process of 10-15 years.
  - **Presence of low cost carrier:** The majority of the selected routes should have competition from low-cost air carriers (LCCs), in order to be able to assess the impact of this. However, it will also be instructive to consider some routes where there is no low-cost air competition, or where there has been a service but it has been withdrawn, in order better to understand the factors leading to these decisions.
  - **Presence of a legacy carrier:** In practice, all routes will have some degree of legacy carrier presence. There will however be differences in the intensity of competition on a given route, which can allow for examination of routes with different market profiles.
  - **Rail journey time:** There is a relatively narrow window in which competition between air and rail is likely to occur. There are very few air routes, of any type, where the rail journey time is below 1.5 hours, as the time taken to access airports and check-in means that in practice air travel will be slower than rail travel. There are currently no routes served by LCCs where the rail journey time is less than 2.5 hours. On these routes, rail competes primarily with other forms of surface transport. However, rail travel rarely competes successfully with air travel of any kind where the rail journey time is more than 4-5 hours. All routes should therefore have a rail journey time that is broadly within the window of 2-5 hours.
  - **Mix of countries:** European legislation brings a degree of harmonization of industry structures in both the rail and air sectors. Nonetheless, different countries' transportation industries still display wide degrees of divergence, including in the degree of market provision, the geographical nature of the demand for transport, government's role in planning and the state of development of the low-cost air market. As discussed above, limitations on the availability of slots at key airports has slowed the development of LCCs in some markets. In order fully to explore all angles of the problem at the European level it will therefore be necessary that the selected routes cover a reasonably wide geographical scope.
  - **Mix of airport locations:** The location of an airport will clearly be a significant factor in its competitive profile, and in which journeys it can realistically cater to.

In London, for example, there are 5 airports, but all are some distance from the centre. This means that it is difficult for air travel to compete with rail on shorter journeys from London. In contrast, Madrid only has one airport, but it is very well located and, after the new terminal is completed during 2006, it will have few capacity constraints.

- **Mix of international and national routes:** Cross-border routes can potentially lead to greater complexity in travel arrangements for a number of reasons, including ease of travel and connection, difficulty in obtaining information and regulatory and technical issues connected with running trains across borders. In addition, journey purpose is likely to be different from that of national journeys. For this reason we propose that a proportion of the routes sampled should cover international journeys.
- **Air rail links:** The purpose of this study is to assess complementarity as well as competition between rail and air travel. It would therefore be useful if, in at least some of the routes, the rail service operated via the airport.
- **Degree of competition:** For a number of reasons, different routes will experience different levels of competition. This may be due to historical factors such as location of transport infrastructure or presence of a dominant operator, to the perceived profitability of the route, or to the strategic importance of a route in an overall network. Clearly it will be important to understand the causes of the level of competition observed on a given route, and to examine a variety of levels of competition.

2.5 The most significant change in the competitive situation on medium distance European routes has been the launch of services by low cost carriers (LCCs) and the significant reductions in ticket prices that have been made by some classic airlines in response. LCCs have resulted in reductions in ticket prices of up to 50% and in airlines abandoning rules which required, for example, passengers to stay over a Saturday night in order to obtain a low fare. The introduction of LCC services means that, for many medium distance routes, air travel is cheaper as well as faster than rail travel. On some routes, LCCs have introduced services successfully even though, for some passengers, the air service is *slower* than rail travel, due to the time taken to access the airport and check in. Therefore, we consider that the availability of a low cost air service, or the possibility that such a service may be introduced, to be a particularly important criteria in selecting routes.

#### **Evaluation of proposed routes against criteria**

2.6 We undertook a preliminary evaluation of the market situation on each of these routes, as far as was possible from public sources. The results of this are set out in the table below.

TABLE 2.1 INITIAL EVALUATION OF ROUTES

Route	Rail journey time	Rail market share (estimated)	Low cost air competition	Airport link	Description of rail service
London-Paris	2:40	68%	Limited (easyJet Luton-Paris, 3-4 flights per day)	No	International service. High infrastructure charges. Journey time to be reduced by approx 20 mins in 2007. High speed line with fairly high frequency but high ticket prices.
London-Brussels	2:20	63%	No (Ryanair and Virgin Express withdrew)	No	International service. High infrastructure charges. Journey time to be reduced by approx 20 mins in 2007. High speed line but with moderate frequency and high ticket prices
Paris-Marseille	3:00	66%	No (easyJet withdrew)	Frequent trains to CDG airport.	Frequent domestic TGV service, entirely using new high speed infrastructure. Medium/low ticket prices.
Paris-Bordeaux	3:00	65%	No	Some trains to CDG airport.	Frequent domestic TGV service, partly using new high speed infrastructure. Medium/low ticket prices.
Madrid-Barcelona	4:40	10% (estimate)	Limited (2 flights per day operated by Vueling)	Link with BCN airport when new line complete, but no link with MAD.	Currently uses high speed line for part of route, but not at high speeds. New line, expected to open in 2008, will reduce journey time to about 2:30. Medium/high ticket prices.
Madrid-Sevilla	2:25	83%	No	No	Frequent domestic AVE service, almost entirely using new infrastructure. Medium/high ticket prices.
Rome-Florence	1:36	90%+ (estimate)	No	No	Frequent domestic Eurostar Italia service, almost entirely using new infrastructure. Low ticket prices.
Frankfurt-Cologne	1:00 (from airport)	90%+ (estimate)	No	All trains run via FRA airport; code share with Lufthansa.	Frequent domestic ICE service, almost entirely using new infrastructure. Medium ticket prices.

2.7 The proposed list covered many of the characteristics set out above as desirable criteria. However, the key area in which the list did not meet these criteria is that these routes generally have little or no LCC competition. Only two routes have any low-cost presence, and in both cases the LCC is a minor player:

- **Madrid-Barcelona:** The legacy carriers Iberia, Spanair and Air Europa achieve a frequency of up to 2 planes per hour, and rail departures operate every 2 hours. In contrast, the only low-cost carrier on the route, Vueling, only operates 2 flights per day
- **London-Paris:** This route is dominated by Eurostar which operates 15 trains per day and the ‘classic’ airlines BA, Air France and BMI which operate around 30 flights per day. In contrast, the low cost carrier, easyJet, operates only 3-4 flights per day.

2.8 However, on many European air routes, low-cost carriers are now dominant, and offer as many flights than classic airlines. The impact of an LCC on a market is likely to be much stronger where it can offer a high frequency: in particular, a high frequency enables an LCC to attract time-sensitive business passengers as well as leisure passengers. The table below identifies the extent of low cost air competition for the top 10 European air routes (measured by 2004 passenger numbers). On half of these routes, LCCs provide more than 12 flights per day, equivalent to approximately one flight per hour during the daytime.

**TABLE 2.2 TOP 10 INTRA-EU AIR ROUTES**

Number	Route	2004 passengers (000s)	Source	Low cost air flights per day	Rail journey time (hours)
1	London - Dublin	4,562	UK CAA	18 (Ryanair)	-
2	Madrid - Barcelona	4,125	AENA	2 (Vueling)	4:40
3	London - Edinburgh	3,581	UK CAA	18 (easyJet / Flyglobespan)	4:10
4	London - Amsterdam	3,493	UK CAA	12 (easyJet)	-
5	London - Glasgow	3,386	UK CAA	17 (easyJet / Ryanair / Flyglobespan)	5:00
6	Milan - Rome	3,264	ENAC	2 (Meridiana)	4:30
7	Paris - Nice	3,077	DGAC	7 (easyJet)	5:30
8	Paris - Toulouse	2,934	DGAC	4 (easyJet)	5:00
9	London - Paris	2,701	UK CAA	3-4 (easyJet)	2:35
10	London - Barcelona	2,202	UK CAA	14 (easyJet / Ryanair)	-

2.9 We found that there was no major air route where an LCC could be considered to be of equal weight to the ‘classic’ carrier and where there was also a high speed rail service. This is because:

- LCCs developed first (and are still strongest) on routes to/from the UK and Ireland, where there are no high speed rail services; and
- Few of the routes on which LCCs provide very strong competition are the type of shorter routes where rail can compete and have high market share.

- 2.10 However, a rail route may have very similar characteristics to a high speed route even if it does not have dedicated new high speed infrastructure. The London-Edinburgh route is a clear example:
- The service offered is similar: a direct service with few stops and a high level of service quality; and
  - The average speed attained is in fact similar to that achieved on high speed lines.
- 2.11 In our view, the use of new high speed infrastructure on a route is not in itself important. A variety of factors will determine mode share, including price and service quality factors, but speed is only relevant inasmuch as it impacts on relative journey time. For example, if we consider the Madrid-Malaga and Madrid-Alicante routes, on both routes the overall offer is similar, with the rail journey time at around 4 hours, and there a train or plane departure about every 2 hours. The Madrid-Malaga rail service runs via a high speed line whereas the Madrid-Alicante route does not, but in this instance the use of high speed rail does not have any significant effect on the relative market position of air and rail transport.

### Route selection

- 2.12 Therefore, we made a number of changes to the choice of routes. On the basis of our initial assessment, we decided to retain the following four routes, which are amongst the largest air/rail routes in Europe measured by passenger numbers:
- Paris-London
  - Paris-Marseille
  - Madrid-Barcelona
  - Madrid-Seville
- 2.13 However, we agreed that three routes should be replaced, largely in order to ensure that the sample of routes includes a number of routes with a viable LCC service, or where such a service could be developed:
- **Brussels-London:** This market is very similar to the Paris-London market and therefore there is limited benefit in studying both. The Paris-London route is more interesting for the purposes of this study as it is significantly larger (in fact it is the largest combined air/rail route in Europe in terms of passenger numbers) and also has some LCC competition.
  - **Rome-Florence:** This route is too short for there to be any viable prospect of LCC competition. There is a limited classic air service operated by Alitalia, but this is primarily in order to feed other connecting services from Rome. The main alternatives to the high speed rail services are the classic rail service and road transport.
  - **Paris-Bordeaux:** This route is very similar to Paris-Marseille in terms of rail journey time and the airline service offer. There is no reasonable prospect of strong low cost air competition, because the difficulty in obtaining slots at Paris airports means that any slots that LCCs can obtain are likely to be used for longer routes. Of the two routes, Paris-Marseille would be more interesting to study because easyJet tried to serve this, and because there is a regular direct high speed rail link from Marseille to Paris CDG airport (there is also a link from Bordeaux,

but services are infrequent).

2.14 After discussion with the Commission and appraisal of a number of other options, we initially substituted these routes with:

- **London-Edinburgh:** Although not technically high speed rail, the rail service on this route is comparable in terms of both service offer and speed to a high speed service. This route is interesting because the main LCC, easyJet, now provides a frequency comparable to either the classic airlines or the railway. The effect of the LCC in this market is therefore very different to that in a market where it operates only one or two flights per day. As LCCs continue to expand, we would expect more routes to acquire these characteristics.
- **Rome-Milan:** This is one of the largest air routes in Europe but rail competition is also strong because of the low ticket prices offered by Trenitalia (even purchasing the ticket one day before travel, we found a fare of €46 available). LCC services are relatively limited, but in the course of our research Ryanair announced that it would serve the Bergamo-Rome route. Part of the rail route uses high speed infrastructure and a new line will open on the rest in 2008/9.
- **Paris-Geneva:** This route currently has three-way competition between classic air, an LCC (easyJet) and high speed rail. We note that the competitive behaviour of the classic airline (Air France) on this route, particularly in terms of pricing, is significantly different from its behaviour on routes where it does not face equivalent LCC and high speed rail competition.

2.15 We also discussed with the Commission whether to retain the Frankfurt-Cologne route, and the reasons for doing so. The rail journey time on this route is very low; there is no LCC offer and, given the low journey time, no realistic possibility of LCC service being introduced. The low cost competition to the high speed rail service is provided by regional trains and road transport. Study of this route therefore does not help answer some of the key questions set out for the study. However, although it was acknowledged that there was no prospect of LCCs providing services on the Frankfurt-Cologne route, we agreed that we would study this route for other reasons:

- Firstly, it would be interesting to study why there are flights between the two airports at all, given the excellent rail offer. Conventional mode share models would predict that there should be no market share for air on a route where the rail journey time is only one hour.
- Secondly, on this route, the airline (Lufthansa) as well as competing with the rail service, co-operates with it. Trains between Cologne and Frankfurt can be booked as part of a through flight (for example, Cologne-Frankfurt-Singapore).

2.16 Therefore our initial selection was as follows:

- Paris-London
- Paris-Marseille
- Madrid-Barcelona
- Madrid-Seville
- London-Edinburgh
- Paris-Geneva
- Rome-Milan

- Frankfurt-Cologne.

### **Change to route selection during the study**

- 2.17 On a number of routes, we encountered difficulties in collection of rail data. In a few cases, there were also issues with obtaining air data, but these could all be resolved. Air passenger data is usually made available by national Civil Aviation Authorities and, in most countries, airlines are required to publish reasonably detailed commercial data. In contrast, equivalently detailed rail passenger and commercial data is rarely available publicly, and therefore we were inevitably more reliant on the assistance of rail operators.
- 2.18 We received assistance from almost all of the rail operators on the case study routes, at least on market issues. However, SNCF was not willing to provide any information or assistance for this study, citing confidentiality. In addition, less rail commercial information is available publicly in France than in many other Member States. This created particular difficulties for the two case study routes where the rail service was operated by SNCF, Paris-Geneva and Paris-Marseille.
- 2.19 In the case of the Paris-Marseille route, we found that some rail information was published as part of assessments that had been carried out in France of the impact of TGV Méditerranée, the high speed line which was completed in 2001. Therefore, we were able to undertake this case study on the basis of largely public information. This limited the scope of the analysis in some areas but nonetheless we believe that it was useful to do it, given the particularly significant effect that the TGV has had on the French travel market. However, for the Paris-Geneva route, there was no equivalent public information and we agreed that in the absence of any assistance from SNCF it was not possible to undertake this case study.
- 2.20 We considered a number of alternative routes, in consultation with the Commission. By this point, a key criteria in selecting the alternative was the possibility of obtaining data within the remaining time available for the study. In particular, it was important that we could obtain rail data, as the air data that we needed was available publicly, albeit at different levels of detail in different Member States. After considering a number of alternatives, we agreed that we would undertake a case study of the **London-Manchester** route. The reasons for doing so were as follows:
- There have recently been significant changes in market share on this route further to a major upgrade of the rail line, including the introduction of fast tilting trains;
  - The operators face some competition from low cost airlines, which is relatively unusual for a route that is so short (the rail journey time has recently been reduced to 2 hours 20 minutes);
  - The rail operator, Virgin Trains, had expressed interest in our study and had kindly volunteered to provide assistance; and
  - Much of the other information that we needed was easily available from public sources.

### 3. LONDON - PARIS

#### Introduction

- 3.1 Eurostar has provided a train service between London and Paris since November 1994. Eurostar services are operated jointly by SNCF, SNCB and London & Continental Railways, which took over the role of British Rail, the former British national rail operator. The trains are owned by each railway and there is no joint company, although there is a joint management team. Eurostar replaced rail/sea connecting services via the channel ports, which were operated until September 1994: these had a journey time of between 6 hours (for travel via hovercraft or catamarans) and 8 hours (for travel via the ferry).
- 3.2 Eurostar faces competition from airlines operating between the London and Paris airports. Most services operate between London Heathrow and Paris Charles de Gaulle (CDG), but there are also services from London Luton to CDG and from London City to Paris Orly. There are currently no air services to Paris from the other two London airports, Gatwick and Stansted.
- 3.3 The service from London Luton to Paris CDG is a low cost air service, operated by easyJet. The other air services are operated by established network carriers. However, one of the three operators on the Heathrow-CDG route, BMI, has adopted many of the characteristics of the low cost operators: for example, it now charges passengers for food and drink, does not offer business class and does not facilitate connecting travel. In this case study, we define BMI as a classic air service, but it is important to note that the distinction between the two types of air operator has increasingly become blurred.

#### Service provision

##### Journey times

- 3.4 The Eurostar service was launched in 1994 with an average journey time of 3 hours and a best journey time of 2 hours 53 minutes. The Eurostar service was limited during the first few months, and a fire in the Channel Tunnel during 1996 resulted in a suspension of services and subsequently extended journey times. A full service has operated since mid 1997.
- 3.5 Eurostar's service was significantly improved from late September 2003, when the first stage of the Channel Tunnel Rail Link (between London and the Channel Tunnel) opened. As discussed in more detail below, reliability improved and journey times were reduced by about 20 minutes: average journey times are now 2 hours 40 minutes and the best journey time is 2 hours 35 minutes. Journey times will be reduced by a further 15-20 minutes in late 2007 when the second stage of the Channel Tunnel Rail Link opens.
- 3.6 Eurostar passengers have to check in 30 minutes in advance to allow for security checks: it is the only European high speed rail service to screen all passengers and their luggage. For full-fare business class passengers, the check-in time is reduced to



10 minutes. The check in time was increased from 20 minutes after the terrorist attacks of September 2001. Figure 3.1 shows the trend in Eurostar journey time.

**FIGURE 3.1 EUROSTAR JOURNEY TIMES**

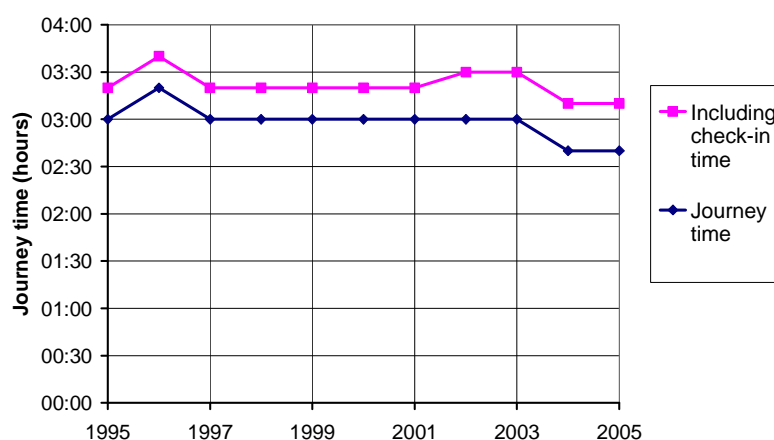

Source: Thomas Cook European Rail Timetable

- 3.7 The air journey time is scheduled to be approximately 1 hour 15 minutes. In practice, the flight time is shorter than this, but both the Paris and London airports are congested and aircraft often need to wait for permission to take off and land.

#### Frequency and available seats

- 3.8 On weekdays, there are currently 35 'classic' air services, 3-4 low cost air services, and 14 direct trains. Since 1995, the number of flights per day has been reduced by 42%.
- 3.9 After the launch of the Eurostar service in 1994, the number of trains was gradually increased and reached 18 direct services per day in 1999, with additional trains running on Fridays and at weekends. However, from 2000 onwards, service frequency was progressively reduced. This was accelerated after the events of 11 September 2001, which resulted in fewer US tourists to Europe, a significant market for Eurostar. Although Eurostar's journey time and reliability improved in 2003, the frequency of the Eurostar service has continued to be reduced, and there is some anecdotal evidence that demand cannot be accommodated at leisure peak periods.
- 3.10 Airline frequencies were reduced between 1995 and 2001, but additional services were added after Eurostar made frequency reductions. However, a number of services have been withdrawn since the opening of the Channel Tunnel Rail Link in 2003, including all services from London Gatwick and Stansted airports to Paris. Low cost air services were launched on this route in 2000 but the number of low cost services has also been reduced since 2003. The trend in frequency is summarised in Figure 3.2 below.

**FIGURE 3.2 RAIL AND AIR FREQUENCY (EACH WAY)**

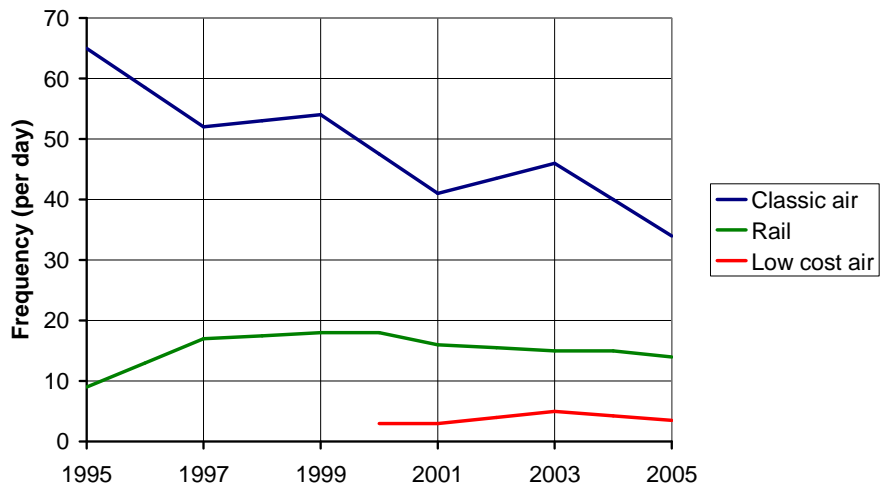

Source: Thomas Cook European Rail Timetable, OAG airline guide

3.11 Eurostar trains have considerably more seats than aircraft. On average, aircraft operating on the London-Paris route have 143 seats; Eurostar trains have 750 seats. Average aircraft size has increased by 15% from 126 seats since 1995, when some flights on this route still used small propeller aircraft: the increase in average aircraft size reflects slot constraints at the London and Paris airports. As a result, Eurostar provides 66% of seats on the route, even though it only provides 27% of frequencies. The trend in seats is illustrated in Figure 3.3 below.

**FIGURE 3.3 RAIL AND AIR AVAILABLE SEATS (TOTAL PER YEAR)**

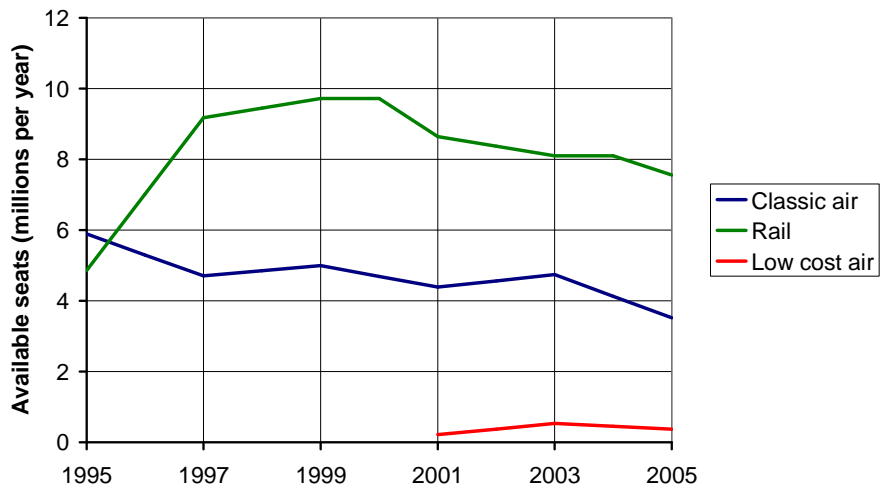

Source: Thomas Cook European Rail Timetable, OAG airline guide

3.12 It should be noted that the reduction in aircraft seats was probably slightly lower than the graph indicates, because most airlines have reduced the proportion of aircraft space designated as business class. It is not possible to track this from published

timetables, however, and this does not significantly change the conclusions of this analysis.

- 3.13 The substantial increase in the number of seats provided by Eurostar between 1995 and 1997 was only slightly offset by a reduction in the number of seats provided by airlines. However, both Eurostar and airlines have reduced capacity since 2000 – Eurostar by around 25% and the airlines by 17%.

### Market size and share

- 3.14 The number of passengers carried by each of the operators over the period since 1996 is shown in Figure 3.4 below. The number of Eurostar passengers on this route has increased from around 3.5 million in 1996 to 5.5 million in 2005. The number of air passengers did not change significantly between 1996 and 2003 but has subsequently declined, further to the opening of phase 1 of the Channel Tunnel Rail Link. Eurostar's market share increased from 62% in 2003 to 69% in 2005.

**FIGURE 3.4 RAIL AND AIR PASSENGERS**

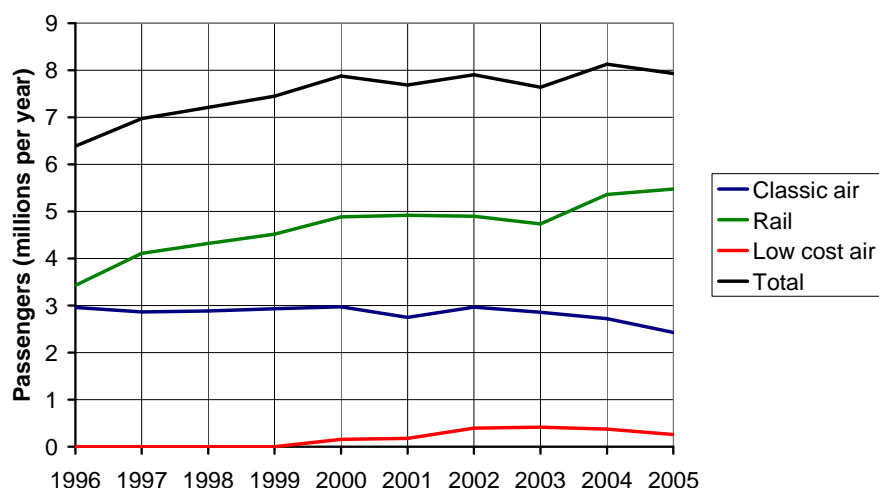

Sources: Data from UK CAA, UK National Audit Office and Eurotunnel; SDG analysis

- 3.15 The total number of passengers travelling on this route increased by 5.4% per year between 1996 and 2000 but has increased by only 0.1% per year since 2000, despite significant increases in the size of the total market for passenger travel between the UK and continental Europe. We discuss below reasons why the size of the London-Paris market has not increased in line with the rest of the market for short haul travel from these cities.
- 3.16 Many of the air passengers on the route are connecting with other air services at either London Heathrow or Paris CDG. The Eurostar terminals are some distance from the airports in both London and Paris and there is no codeshare or other commercial arrangement between Eurostar and the airlines; as a result, Eurostar cannot compete for these passengers. Almost half of airline passengers on the London-Paris route were connecting at either the London or Paris airports in 2003. A small proportion of Eurostar passengers connect onto other long distance rail services at either London or

Paris: no up to date data is available for this, but based on data from 1998, we estimate this to be less than 10% of Eurostar passengers.

**FIGURE 3.5 CONNECTING AND POINT-TO-POINT PASSENGERS (2003)**

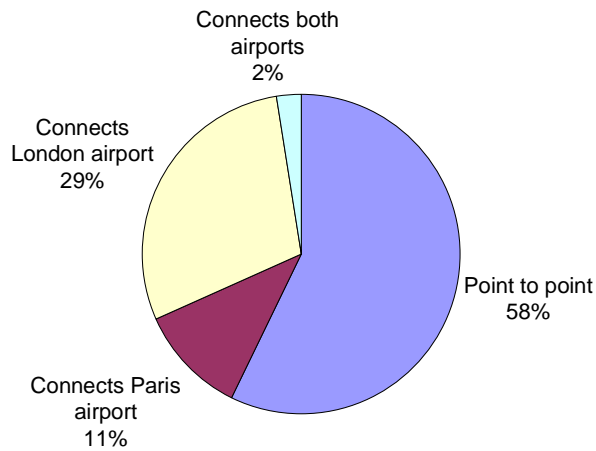

Sources: UK CAA air passenger surveys, Eurotunnel

3.17 Taking this into account, Eurostar’s market share is even higher than indicated above; the low cost air share is also higher, as 90% of low cost airline passengers were making point-to-point journeys. We estimate that Eurostar carried about 72% of point-to-point passengers in 2003, compared to 62% of the total market. Although we do not have access to equivalent data for connecting passengers for years since 2003, based on the trend in the number of passengers carried by each operator, we estimate that Eurostar’s share of the point-to-point<sup>1</sup> market is now likely to have reached approximately 80%.

**FIGURE 3.6 MARKET SHARE (2003)**

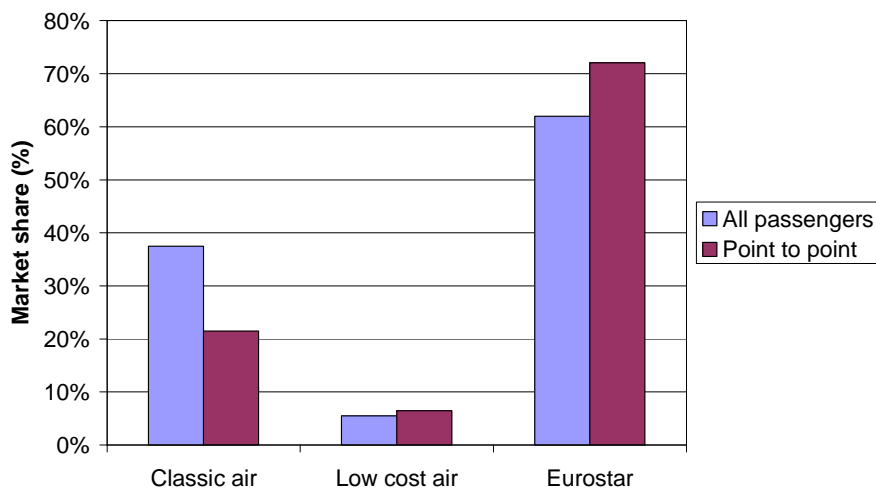

<sup>1</sup> By point-to-point we mean passengers whose ultimate origin and destination are the cities of London and Paris and the surrounding regions.

Source: SDG analysis

- 3.18 In addition to rail and air travel, car and bus travel is possible, although as it is necessary to cross the Channel, using either a ferry or the Eurotunnel Shuttle service, this is relatively unattractive. Bus fares on the route are very low (as little as €15 return) but the journey time is 7-8 hours, much longer than by air or rail. No data is available for the proportion of passengers travelling by bus or car.

### **Access to the services**

London

- 3.19 The origin and destination of the passengers is a key factor affecting market share. shows the market share of air and rail transport by origin area in southeast England. The figure below shows current Eurostar terminals (Waterloo International in central London, and Ashford in Kent), as well as the future Eurostar terminals, are highlighted.



FIGURE 3.7 RAIL MARKET SHARE BY ORIGIN AREA (2003)

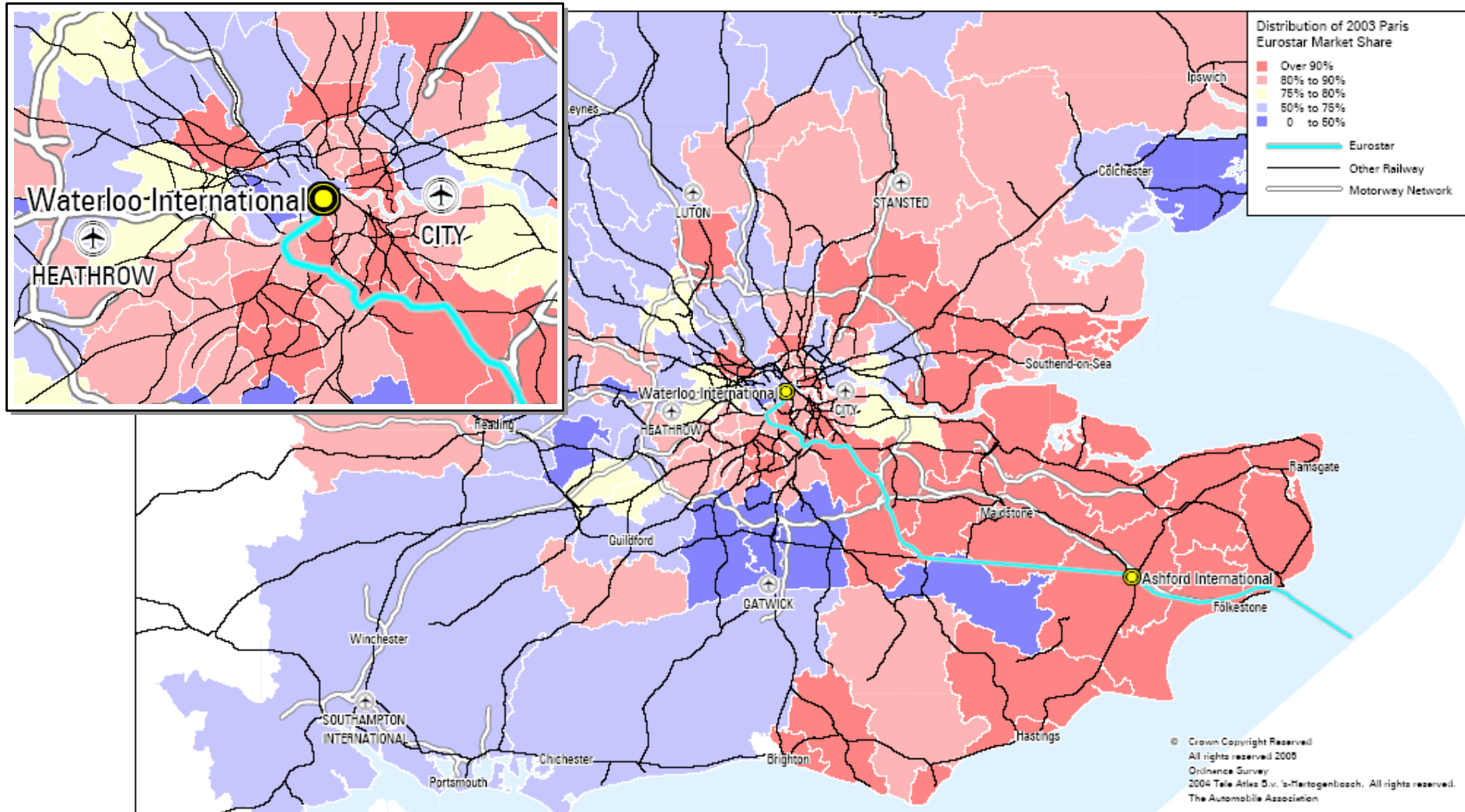





- 3.20 This analysis is based on surveys of air passengers undertaken by the UK CAA. No equivalent data are available for Eurostar, but we have estimated the origins/destinations of Eurostar passengers by comparing the distribution of passengers on short haul air routes where there is no rail alternative with the distribution of air passengers on the Paris route. Eurostar's share is much higher for passengers travelling to/from the areas closer to its terminals; its share is lower for travel from areas north and west of central London, from which it is more convenient to access the airports.
- 3.21 The table below shows that a substantial proportion of the passengers for London-Paris air and rail services do not actually travel to/from central London, or indeed to or from London at all. 59% of the population of the London airports catchment area is outside London; 44% of actual passengers travel to/from destinations outside London. Only about 20% of passengers travel to/from central London.

**TABLE 3.1 DISTRIBUTION OF POPULATION AND PASSENGERS - LONDON**

	Passengers' origins and destinations			Distribution of population	
	Air	Eurostar	Total market	Population (000s)	%
London - Central	29%	17%	20%	908	5%
London - Inner suburbs	7%	14%	12%	2,023	11%
London - Outer suburbs	18%	25%	23%	4,497	25%
Total London	54%	56%	56%	7,429	41%
Southeast outside London	46%	44%	44%	10,901	59%

Sources: UK CAA, Office of National Statistics

- 3.22 The London airports are accessible from the city centre via rail, underground and bus. Heathrow Express operates a quarter-hourly express rail service between Heathrow Airport and Paddington station in the city centre; Stansted, Luton and Gatwick airports are connected to London's main rail stations by direct train services; and London City airport is located six miles away from the city's financial district. Waterloo International station is located in the city centre and is a hub for national rail, underground and bus services.
- 3.23 Table 3.2 below shows public transport and car access times from the city to the terminals. We show the following:
- access times and costs by public transport from the city centre;
  - weighted average public transport access times from the city, taking into account the distribution of population; and
  - weighted average car journey times.
- 3.24 This analysis shows that the Eurostar terminal at Waterloo is significantly more accessible from the key population centre than any of the airports, particularly by public transport. However, it is unattractive to access the terminal by car: although parking costs are low, there is severe road congestion in London, and passengers

accessing by car would have to pay the central London congestion charge (£8 / €11 per day).

**TABLE 3.2 ACCESS TIMES AND COSTS TO LONDON TERMINALS**

Terminal	Access by public transport from city centre		Weighted average public transport time (minutes)	Access by car (all areas)	
	Cost (£)	Journey time (minutes)		Drive time (minutes)	Parking fees (24 hours at terminal)
Heathrow	£13.50 (Heathrow Express) £4 (metro)	15 / 60	67	69	£43
Gatwick	£14 (Gatwick Express) £9 (other rail)	30	54	77	£18.50
Luton	£11.50 (rail)	45	80	79	£25
Stansted	£15 (rail)	45	69	78	£20
City	£3 (Docklands Light Railway)	25	55	81	£20
Waterloo International	n/a	n/a	29	n/a	£17
Ashford International	n/a	n/a	n/a	117	£9.50

Source: TfL journey planner; Nationalrail.co.uk

### Paris

3.25 In comparison with London, there is a higher concentration of population in central Paris (19% compared to 5%). 37% of Parisians live in the inner suburbs, whereas 44% live in the outer suburbs. Data for passenger distribution in Paris is not available but we would expect a higher proportion of demand to be for travel to central Paris than for central London: in part, this is because there are more tourist trips from London to Paris than vice versa, and tourists tend to stay close to or in the centre. We would expect that 40% of passengers would be travelling to/from central Paris.

3.26 The average access times and costs to each of the Paris terminals, from the city centre, are as follows. Travel times to the Eurostar terminal are not available, since Gare du Nord is located in the city centre.

**TABLE 3.3 ACCESS TIME AND COSTS TO PARIS TERMINALS**

Terminal	Rail time (minutes)	Rail cost	Drive time (minutes)	Parking fees (24 hours at terminal)
CDG	35	€8	45	€15-€23
ORY	45	€5.65- €9.05	35	€11.7-€21.2
Gare du Nord	n/a	n/a	n/a	€22-€26

---

### Check-in times

- 3.27 Most of the classic airlines recommend that passengers check in one hour prior to departure. On-line check-in services are available to British Airways passengers on any ticket type (e.g. e-ticket, cardboard ticket, paper ticket). London City Airport allows passengers to check in up to 10 minutes before scheduled departure.
- 3.28 easyJet recommends passengers check in two hours before departure and check-in desks close exactly 30 minutes before the scheduled departure of the flight. Late passengers are not allowed to board the flight and must forfeit their seat. In addition, easyJet's free seating-policy and boarding procedures imply that the earlier a passenger checks in, the wider of choice of seats s/he would have on-board. However, easyJet has also recently announced on-line check-in for passengers travelling with hand luggage only: these passengers will be required to reach the gate 15 minutes before departure, although this still implies arrival at the airport at least 30 minutes in advance, given the time necessary to pass through security.
- 3.29 Eurostar requires that passengers check in 30 minutes prior to departure to allow for security checks (10 minutes for maximum price business class ticket holders). The check-in time was raised from 20 to 30 minutes in late 2001: Eurostar now screens all passengers and their luggage; previously, it screened a proportion of passengers. However, arrivals have been accelerated as passport checks now take place before boarding, not on arrival.

### Airport connections

- 3.30 The Eurostar terminals in London and Paris are both significant distances from the main airports and there is no commercial agreement between Eurostar and the airlines to facilitate connecting travel. In London, the connection requires use of two metro lines and in Paris, connecting passengers would have to use the RER suburban rail service and (depending on the terminal) an onward bus shuttle. As a result, we would not expect that a significant number of passengers makes connecting journeys between Eurostar and air services.
- 3.31 In principle, it would be possible to run a Eurostar service between London and Paris CDG airport and there is a daily train from London to Marne-la-Vallee (for Disneyland Paris) which passes through CDG airport station. When the UK Channel Tunnel Rail Link is complete, the journey time from central London to CDG airport could be little over 2 hours, and the journey time from the Ebbsfleet station on the outskirts of London to CDG could be under 2 hours. However, there are currently no plans to run such a service and Eurostar management informed us that they did not believe that such a service would be attractive to business passengers.
- 3.32 A key constraint on the operation of trains from London to CDG airport is that Eurostar trains have very high capacity (750 seats) and it is not possible to run shorter trains due to the safety regulations applying for operations through the Channel Tunnel. It would be necessary to operate a minimum of 4-5 trains per day in each direction in order to enable passengers to connect onto a reasonable proportion of flights. There is simply not enough traffic to justify use of such high capacity trains to provide airport connecting traffic. A typical Air France aircraft on the London-Paris

route carries 40-50 passengers connecting on to other flights at CDG, but a Eurostar train would have to carry 400-500 passengers for the operation to be commercially attractive.

### Fares

#### Level of fares

3.33 In order to estimate the “average” fares that passengers pay, we have compared fares on the London to Paris route for over 100 potential journey combinations. While our sample was designed to be representative of the types of journeys passengers typically make, we cannot be certain that it covers all types. We found that the average sampled fares on Eurostar were close to the average fares on most of the network airlines (see Figure 3.8) below. However, the one low cost airline on the route, easyJet, charged 60% less than either the classic airlines or Eurostar (€35). The fares shown include all taxes, fees and charges.

**FIGURE 3.8 LONDON – PARIS AVERAGE SAMPLED FARES**

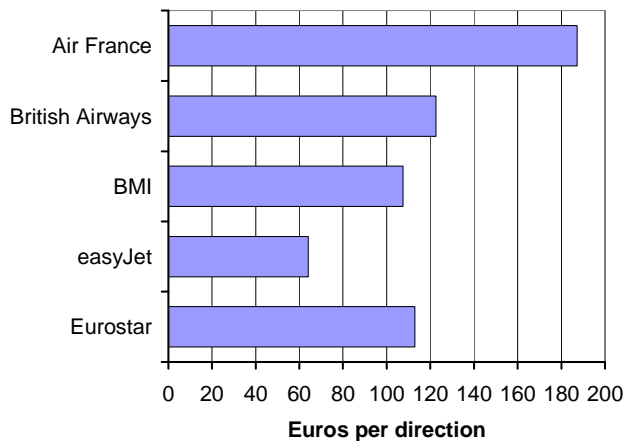

Source: Operator websites

3.34 There is significant variation in fares between different journey times and travel options (for example, single and return tickets). Figure 3.9 compares fares for two specific journey types – a return journey over a weekend booked 2 months in advance (typical for a leisure passenger), and an overnight journey booked 3 days in advance (more typical for a business passenger). In both cases, Eurostar fares were in line with the classic airlines, but easyJet’s fares were considerably lower than either.

FIGURE 3.9 LONDON – PARIS RETURN FARES

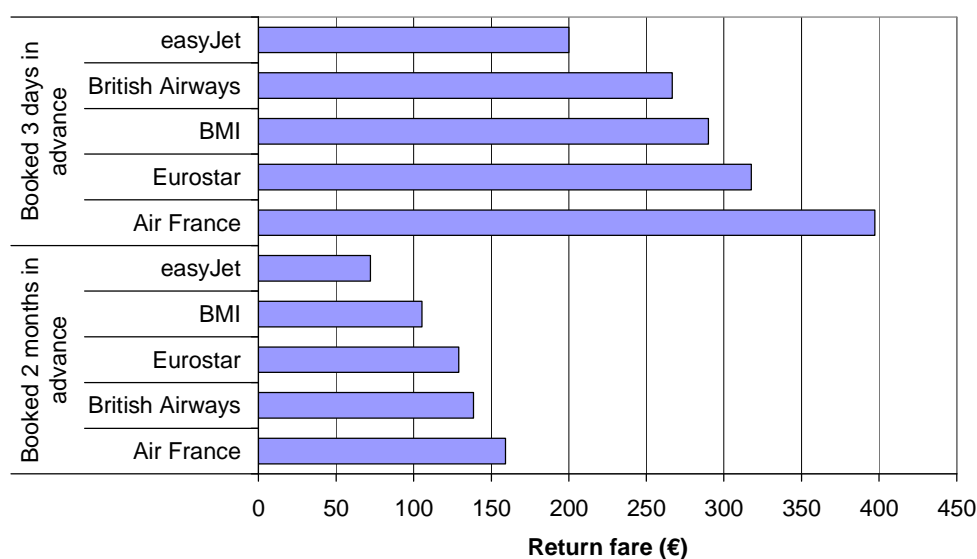

- 3.35 Eurostar operates a reasonably flexible revenue management system, similar to that used by certain airlines. This uses an inventory control system and relates the price for most types of tickets with the amount of spare capacity available on a train-by-train basis. This gives it an advantage relative to some other rail operators which do not vary price significantly or in some cases at all, and therefore can be disproportionately expensive relative to the airlines at off-peak times or for passengers that book less well in advance. Eurostar's management considers that the introduction of this system in 2003 made an important contribution to improving its market share.
- 3.36 However, in some other respects Eurostar's tickets were much less flexible than those offered by airlines, particularly the low cost airline easyJet. easyJet, in common with other low cost airlines, sells all tickets as single tickets; there is therefore no restriction such as a requirement for passengers to make a return trip or stay over a Saturday night in order to obtain a discounted fare. easyJet's tickets can also be changed by passengers on payment of an administration fee. Most of the full service airlines appeared to have adopted this at least parts of this model, but Eurostar had not: single or 'open jaw' tickets are not available at discounted rates, a Saturday night stay is required for many tickets purchased less than 3 weeks in advance, and discounted tickets are completely inflexible.
- 3.37 Rail and air fares on the London to Paris route are high compared to air fares from London to other parts of continental Europe. Rail fares from Paris to London are also high compared to rail fares from Paris to other parts of France and other near-European destinations. This is an important limitation on the size of the market, for two reasons:
- Discretionary leisure travel, particularly by UK residents, accounts for a high proportion of demand. For these trips, competition is as much between destinations as between modes. The fact that rail fares on this route are relatively high means that some passengers who might otherwise have travelled to Paris or London instead travel to other destinations.

- Many other journeys can be made via Eurostar with one change of trains – for example, Leeds-Paris or London-Amsterdam. However, as Eurostar fares are relatively high, and these connecting journeys are generally more expensive than the basic London-Paris trip, rail is unattractive in terms of price as well as journey time for these longer journeys.

3.38 We also found that Eurostar tickets sold in France are generally cheaper than those sold in the UK, for two reasons:

- There is more demand for UK originating travel than travel originating in France. As a result, trains are busier at UK travel peaks (eg. Friday out of London, Sunday returning to London), and as a result of the application of the yield management system, fares are higher at these times.
- Eurostar's standard fares are lower in France. The lowest return fare in the UK is £59 (€85) whereas the lowest return fare sold in France is 70€, 18% less. The difference is more extreme for single tickets: the cheapest single ticket sold in France is €35, whereas the cheapest ticket sold in the UK is £149 (€216). In this respect, Eurostar appears to be unfairly discriminating against passengers that live in the UK.

#### Purchasing tickets

3.39 All of the operators on the route allow tickets to be purchased on their website, and all of the operators charge higher fees for booking by telephone (except Air France, for which the fares we obtained by phone were lower). easyJet and two of the classic airlines (British Airways and BMI) charged passengers extra for booking with a credit card, but neither Eurostar nor Air France did so.

3.40 Whilst all of the airlines offer e-tickets, Eurostar does not. It does not levy any additional charge for paper tickets, but if the booking is made within 7 days, these must be collected from the terminal. This creates problems for non-French residents making journeys originating in France as a French credit card is required. This policy also prevents non-French residents from buying the cheaper tickets it sells in France.

#### Service quality and on board services

3.41 The table compares various service quality characteristics for Eurostar and the airlines, and the terminals that these serve. The Eurostar stations are comparable to airports in that passengers have to pass through security and can then wait in a secure, heated lounge. However, the on-board service (at least in 2nd class) is comparable to a conventional train rather than an aircraft. In some respects this is positive – the baggage limit is much more generous, for example – but in others it is less so – passengers have to pay extra for food and drink. The low cost airline, easyJet, provides a less generous seat pitch, charges for food and drink, and does not offer pre-assigned seating, but in other respects the service is equivalent to the other airlines.

TABLE 3.4 SERVICE QUALITY AND ON-BOARD SERVICES

	Eurostar	Classic airlines	easyJet
<b>On board service quality</b>			
Seat pitch (economy/standard class)	Approx 80cm	77-78cm	72-73cm
Catering included (economy/standard class)	✘	Snack/drinks (ex BMI)	✘
Check in baggage limit	N/A 2 items max on train	20kg	20kg
Pre-assigned seating	✓	✓	✘
Magazine available	✘	✓	✓
1st/business class available	✓	✓ (ex BMI)	✘
Key differences in 1st/business class	Larger seat 3 course meal Newspapers Power points	Larger seat Larger meal	N/A
Typical price surcharge for 1st/business class	50-100%	100-400%	N/A
<b>Airport / terminal facilities</b>			
Catering facilities	✓	✓	✓
Retail outlets	✓	✓	✓
Heated/secure waiting lounge	✓	✓	✓
Toilets	✓ (charged for pre-security, free post-security)	✓ (free)	✓ (free)
Business lounge available	✓	✓	✘
Business lounge open to all 1st class passengers	✘	✓	N/A

### Reliability

3.42 Figure 3.10 shows the punctuality of air services on the London-Paris route and of the Eurostar train service. Eurostar is significantly more punctual than the air services. On this route, there is little difference between the punctuality of the low cost air operator, easyJet, and the classic airlines, Air France, British Airways and BMI. The most punctual air service is the Air France service from London City Airport to Paris Orly, as this avoids congestion at Heathrow and CDG. It should be noted that the reliability figure for Eurostar covers all Eurostar services and so does not distinguish between the London-Paris route and the London-Brussels route.

FIGURE 3.10 PUNCTUALITY ON LONDON-PARIS ROUTE (2004)

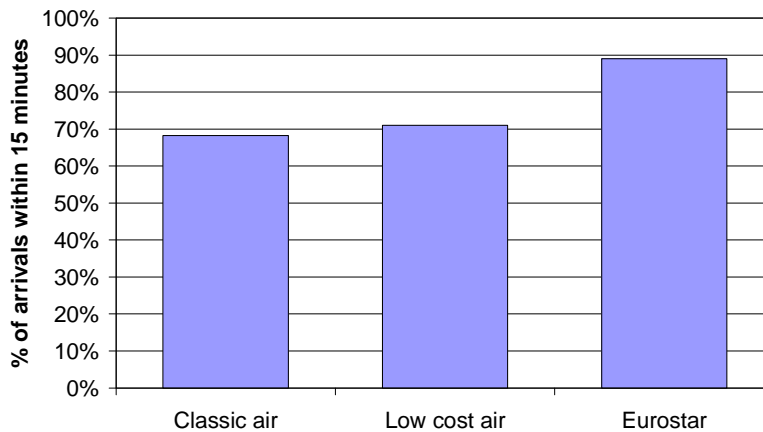

Source: UK CAA, Eurostar

3.43 Changes in reliability have had a noticeable impact on market share at certain points. Eurostar's market share declined from 64% to 62% between 2001 and 2002, partly as a result of significant reliability problems after the Hatfield rail accident in the UK. These problems culminated in a suspension of the service for several days in October 2002 due to salt on the overhead wires in northern France, which left many passengers stranded overnight on trains, and led to significant negative publicity. Improvements in Eurostar reliability have almost certainly contributed to the improvements in its market share since the opening of phase 1 of the Channel Tunnel Rail Link in 2003: the proportion of its trains arriving within 15 minutes of the scheduled time increased from 79% to 89%. Eurostar's management informed us that they believed that reliability had been even more important than journey time in enabling Eurostar to achieve increased market share after the opening of the Channel Tunnel Rail Link.

3.44 The Eurostar service has been relatively free from strikes and other major disruption. Eurostar services have continued to operate during most strikes that have taken place on SNCF. In contrast, the airlines have experienced more difficulties: all airlines were affected by an air traffic control strike in France in February 2006, and there have been various strikes amongst airline staff which have disrupted services. The low cost air services between London and Paris have also not been disrupted by airline strikes but there has been disruption at various points to some of the legacy airlines, for example:

- In August 2005, all British Airways operations at London Heathrow were suspended for 24 hours due to a strike, and there was severe disruption for a further 2-3 days;
- Air France services to Paris Orly airport were suspended due to a strike for 4 days in February 2005 and many services have been disrupted by general strikes in France, such as the strike in October 2005.



## Taxes and subsidies

### Railways

- 3.45 Eurostar is operated jointly by the French and Belgian railways SNCF and SNCB, and Eurostar UK Ltd (EUKL), which is owned by London & Continental Railways, which took over the international obligations of the former British state railways. There is no integrated operating company and no single set of accounts is available. The French railways (SNCF) do not publish any information about their holdings in Eurostar but information is available for EUKL. EUKL has received significant direct and indirect subsidies:
- Rolling stock purchased and other assets constructed for the Eurostar service (such as the terminal at London Waterloo) were provided at zero cost to Eurostar UK by the UK government.
  - The UK government has guaranteed the access charges to be paid by Eurostar UK for use of the Channel Tunnel Rail Link. This enabled construction of the rail link to be financed.
  - The UK government paid direct subsidy to London & Continental Railways, which is constructing CTRL and which owns Eurostar UK.
- 3.46 Despite these significant indirect subsidies relating to the launch of the service, Eurostar incurs significant losses. Press reports indicate that the total Eurostar company lost around €160 million in 2002. This loss is likely to have been much greater in subsequent years due to the substantial access charges that it has to pay to use the UK Channel Tunnel Rail Link: the access charge in 2004 was €220 million implying a total loss of up to €360 million. Based on reports by the UK National Audit Office, we estimate that EUKL lost about €260 million in 2004, largely as a result of having to pay total access charges of €370 million. EUKL would probably be profitable if access charges only recovered marginal costs, although this is not transparent. In effect, EUKL's loss is covered by the UK government, albeit indirectly, through its guarantee of the debts issued by London & Continental Railways and the direct subsidy paid to it.
- 3.47 Any loss made by SNCF on its share of Eurostar would be offset by profits on other services or paid by the French government as part of its general subsidies to SNCF. However, the process by which this is covered is not transparent.
- 3.48 The rail operators do not pay fuel taxes and VAT is not levied on rail tickets in either the UK or France.

### Airlines

- 3.49 The airlines operating between London and Paris do not receive operating subsidies and such subsidies are not permitted under European law. However, Air France did receive FF 20 billion in state aid in 1994 to assist with restructuring. None of the other airlines operating on the route have received state aid.
- 3.50 Airline passengers pay UK air passenger duty (£5, approximately €7) and French civil aviation taxes of around €12, per return trip. However, tickets are exempt from VAT and, in common with other routes, the airlines do not pay fuel taxes.

### Future developments

- 3.51 The second stage of the Channel Tunnel Rail Link (CTRL) will open in 2007, enabling Eurostar services to operate at high speeds to the centre of London. The fastest Eurostar journey time will be reduced to 2 hours 15 minutes (from 2 hours 35 minutes), although the average journey time will be longer than this. At the same time, Eurostar will switch to St Pancras station from its current terminus at Waterloo, and additional stations will open at Stratford (in East London) and Ebbsfleet (outside London close to the M25 orbital motorway). We estimate that the opening of the second stage of CTRL will increase Eurostar's market share by about 5 points, and Eurostar's management informed us that it intends to run additional trains from this point. However, the impact on demand will be dependent on whether it further increases its fares, which (as set out above) are already high.
- 3.52 In principle there could be a market for new Eurostar services, including a service from London to Paris CDG airport and a service to Amsterdam. However, Eurostar has no plans to introduce any additional services.
- 3.53 It is possible that easyJet will launch a service from London Gatwick airport to Paris (possibly in place of the existing service from Luton airport) when Eurostar transfers its service to St Pancras, as the new terminal will be less attractive for those living south of London. This will depend critically on the level of fares Eurostar sets. It is also possible that some of the existing air services from London City airport may stop operating when the Eurostar station at Stratford opens, although this will depend both on the level of fares set by Eurostar and the frequency of service it provides at Stratford.

### Conclusions

- 3.54 Eurostar provides a high quality direct rail service between London and Paris. As well as being faster than air travel for most city to city journeys, it is also significantly more reliable. As a result, it has obtained a market share of almost 70%. and a share of nearly 80% of the total rail/air market. There is a relationship between journey time and market share: Eurostar's market share improved significantly after the opening of the first part of the Channel Tunnel Rail Link in September 2003, and can be expected to improve further in 2007, when the second stage of the Channel Tunnel Rail Link opens; however, significant improvements in reliability also contributed to this.
- 3.55 Eurostar's market share is lower than rail obtains on other routes with comparable journey times, and given the poor location of the main London and Paris airports relative to the cities, Eurostar's market share might be expected to be better than it is. In our view, there are two main reasons for this:
- Eurostar fares are high; and
  - Passengers have to check in 30 minutes in advance, offsetting part of the journey time advantage.
- 3.56 The total size of the London-Paris market has not grown significantly since 2000, and this also reflects the trend in fares on the route. Whilst air fares on other routes from the UK have fallen significantly due to the launch of new services by low cost airlines,

the fares charged by Eurostar (the main operator) appear to have increased. Relatively high fares also mean that rail travel is not competitive in terms of price with air travel for longer journeys between the UK and continental Europe (such as London-Lyon or Birmingham-Paris), all of which require travel via Eurostar and therefore purchase of both a Eurostar ticket and a connecting rail ticket.

- 3.57 It is also important to note that the Eurostar service has received significant subsidies. Its tax position is also more advantageous, as there is no tax levied on its tickets, but both the UK and French government levy taxes on air tickets. Despite this, Eurostar does not appear to be profitable (as discussed in the operating cost section of our main report). In contrast, the airlines operating on the route do not receive subsidies and operate profitably despite offering lower fares.

## 4. MADRID - BARCELONA

### Introduction

- 4.1 The Madrid-Barcelona route is the second largest air route in Europe (after London-Dublin), measured by passenger numbers. The distance between Madrid and Barcelona is too great for surface transport to be competitive, particularly as speeds on the Spanish conventional rail network are low by European standards. Very high frequency air services are provided, with the largest carrier (Iberia) operating 4-5 flights per hour at peak times and at least two flights per hour throughout the day on weekdays. There is also a train service every 2 hours during the day, and one overnight service.
- 4.2 At the time we conducted this research, RENFE, the Spanish national rail operator, provided the rail service between Madrid and Barcelona with Alaria-branded trains; these have subsequently been replaced, as discussed below. A high speed line is currently used for part of the route, but trains do not operate at high speeds. The high speed line is expected to be completed at the end of 2007 and enter into service in early 2008, which will reduce rail journey time significantly. However, due to various technical problems with the construction of the line and the signalling system, it is not certain that the journey time will be as low as originally planned (2 hours 25 minutes).
- 4.3 There are three classic carriers operating on the route, Iberia, Spanair and Air Europa. Although these are classic network airlines, the standard of service offered by Spanish airlines on domestic routes has long had many of the characteristics of a low cost airline. At present, Vueling is the only low-cost carrier (LCC) operating on the route, and is a minor player in this market, currently operating only 2 flights per day.

### Journey times and frequencies

#### Journey times

- 4.4 The rail journey time between Madrid and Barcelona is approximately 5 hours, although, at the time of our research, one train in each direction per day completed the journey in 4 hours 35 minutes. Trains between Madrid and Barcelona currently travel on the high speed line between Madrid and Lleida in western Catalunya, where they change from standard to broad gauge in order to use the conventional network between Lleida and Barcelona. The combination of the gauge change and the slower speeds on the conventional network means that the journey time from Lleida to Barcelona is a minimum of 2 hours (often longer), despite a distance of only 160km.
- 4.5 The Madrid-Barcelona journey time was reduced by 2 hours in October 2003 as result of the opening of the new high speed line between Madrid and Lleida. This also resulted in the transfer of the rail terminal from Madrid Chamartín, on the north of the city centre, to the (better located) high speed rail station at Puerta de Atocha. Further to the completion of our research, RENFE has replaced the Alaria trains on the route with new Alvia trains. These trains complete the gauge change more quickly and, as a result, journey times have been reduced by 15 minutes.

- 4.6 The Lleida-Barcelona section of the line is currently under construction and is due to open in 2008. It was originally planned that the rail journey time for the Madrid-Barcelona route could be as little as 2 hours 25 minutes, using trains with a maximum speed of 350km/h. However, there has been a series of technical problems with the line, resulting in significant delays to construction, and the maximum speeds are now expected to be lower than originally planned. In particular, it was planned that the line should use the new ERTMS signalling system, but this does not work and the line has been equipped with a temporary system. Rail journey times since 1995 are summarised in Figure 4.1.

**FIGURE 4.1 AVERAGE RAIL JOURNEY TIMES**

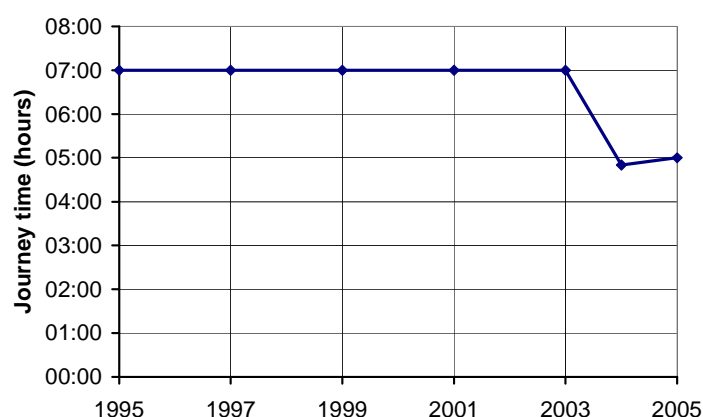

Source: Thomas Cook European Rail Timetable

- 4.7 Scheduled air journey time on the route is 70-75 minutes. The actual flight time is around 55 minutes but the aircraft are scheduled to take longer, and in practice there are often significant delays due to congestion at Madrid airport.

#### Frequency and available seats

- 4.8 On weekdays there are currently 6 rail services, 63 classic air and two low cost air services per day on this route. Over 60% of the flights are operated by the Spanish flag carrier Iberia, and a further 30% are operated by Spanair; the remainder of the services are provided by Vueling and Air Europa. We classify the airlines (other than Vueling) operating on this route as classic rather than low cost carriers, but the service offered by Spanish airlines on domestic routes has long had many of the characteristics of a low cost airline. For example, Iberia was the first major European carrier to introduce charges for catering in economy class.
- 4.9 Whilst the number of trains has been reduced by two per day since 1995, air service frequency has increased by 34% over the period (although air frequency has also declined slightly since 2003, when it peaked at 70 per day). The number of flights operated by Spanair has expanded significantly, from 8 per day in 1995 to 18 in 2005.
- 4.10 However, beyond this, the nature of the air services provided between Madrid and Barcelona has not changed significantly in the past decade: ten years ago the three

main airlines on the route were also Iberia, Spanair and Air Europa, of whom Iberia was the dominant. Trends in overall service frequency are illustrated in Figure 4.2.

**FIGURE 4.2 RAIL AND AIR FREQUENCY (EACH WAY)**

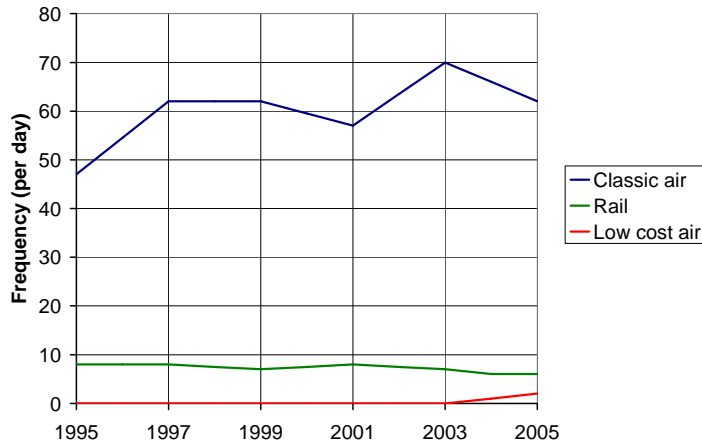

Source: Thomas Cook European Rail Timetable, OAG airline guide

4.11 Although the trains operated on the route have larger capacity than the aircraft, rail capacities are low in comparison with other major European routes. Most trains operating on the route are Talgo units with a capacity of around 220 seats, although longer trains are occasionally operated during peak periods. The large difference in frequencies means that air dominates rail for capacity between the two cities. Most aircraft used are A320/321s or MD80 series aircraft, with an average capacity of about 150 seats, 5% less than in 1995, but in practice capacity is equivalent when we take into account the fact that less of the aircraft is now usually used as business class. The effect of this slight reduction in aircraft size is minor when compared with the effect of expansion in the number of services. This is illustrated in Figure 4.3.

**FIGURE 4.3 RAIL AND AIR AVAILABLE SEATS (TOTAL PER YEAR)**

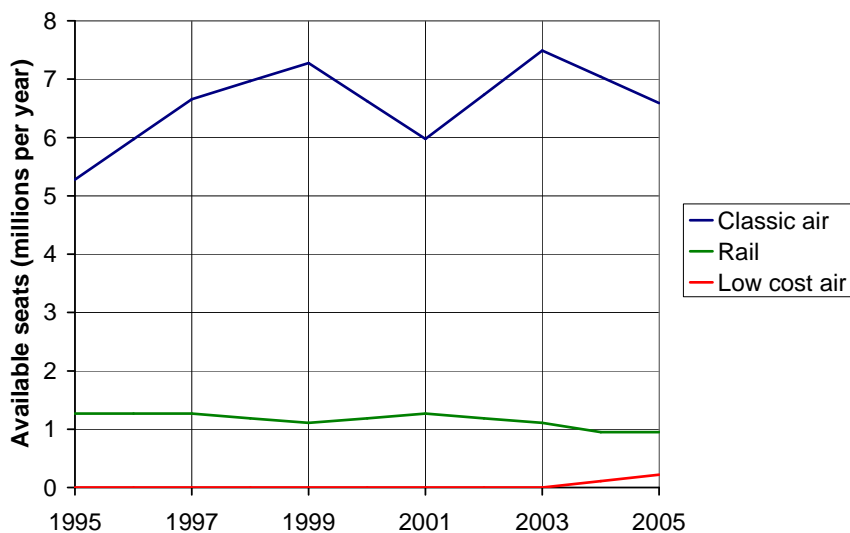

Source: Thomas Cook European Rail Timetable, OAG airline guide

- 4.12 It should also be noted that not all of the rail capacity will be used by passengers travelling between Madrid and Barcelona. Some passengers will embark and disembark at the intermediate stops which on the route, particularly Zaragoza.

#### The Puente Aereo

- 4.13 Iberia operates an ‘air bridge’ (Puente Aereo) between Madrid and Barcelona, and this accounts for 70% of its passengers. It operates at least twice per hour throughout the daytime and up to four times per hour at peak periods. Passengers do not reserve seats on a specific flight but buy tickets that are valid for one year and use the next flight available when they arrive at the airport. The Puente Aereo uses separate check-in, security and gate facilities, in order to allow a much lower minimum check-in time than other services (20 minutes compared to 45 minutes for other domestic flights at Madrid terminal 4). In practice, it can be possible to check in 5-10 minutes before scheduled departure.
- 4.14 The Puente Aereo service is unique in Europe and reflects the exceptionally high volume of air passengers on the route. The Madrid-Barcelona air route is the second largest in terms of passenger numbers in Europe after London-Dublin, and is the largest if measured in terms of airport pairs rather than city pairs (London-Dublin flights are divided between five airports in the London area).
- 4.15 In addition Iberia operates about 12 normal scheduled services per day. These are cheaper, particularly for passengers that book in advance, and are also used by passengers connecting onto other Iberia services at Madrid. Some use the same flight numbers as Iberia long haul services and serve the international pier at the Iberia terminal at Madrid (terminal 4).

#### Bus competition

- 4.16 Historically, buses rather than trains have provided the main mode of long distance public transport in Spain. Total bus passenger kilometres within Spain are 2.5 times rail passenger kilometres – in contrast to other countries such as France, where the number of rail passenger kilometres is nearly twice the number of bus. This is because on many routes, bus journey times are equivalent to or better than rail journey times, and unlike many European countries, Spain does not impose regulatory limits on bus competition with rail (bus routes are regulated but on a concession basis).
- 4.17 RENFE believes that competition with road transport is more important than competition with air transport except on routes with journey times of less than 3 hours. There are currently 20 scheduled buses per day between Madrid and Barcelona, with a scheduled journey time of around 7 hours, including refreshment breaks. Multiple buses run when required given the level of demand, so the actual capacity is greater than this. Many buses run non-stop. Although we do not have figures available, we would expect the number of bus passengers for the Madrid-Barcelona route to equal and probably exceed the number of rail passengers. We do not have access to historical bus timetables which would enable us to track whether the bus service offer has changed over time.

## Market Share

### Market Size

- 4.18 Figure 4.4 shows the trend in the number of passengers carried by each type of operator on the route since 1999. The total market for air and rail travel between Madrid and Barcelona grew by 31% between 1999 and 2004; rail now has a market share of 10.1%, an increase from 6.4% in 2003.

**FIGURE 4.4 RAIL AND AIR PASSENGERS**

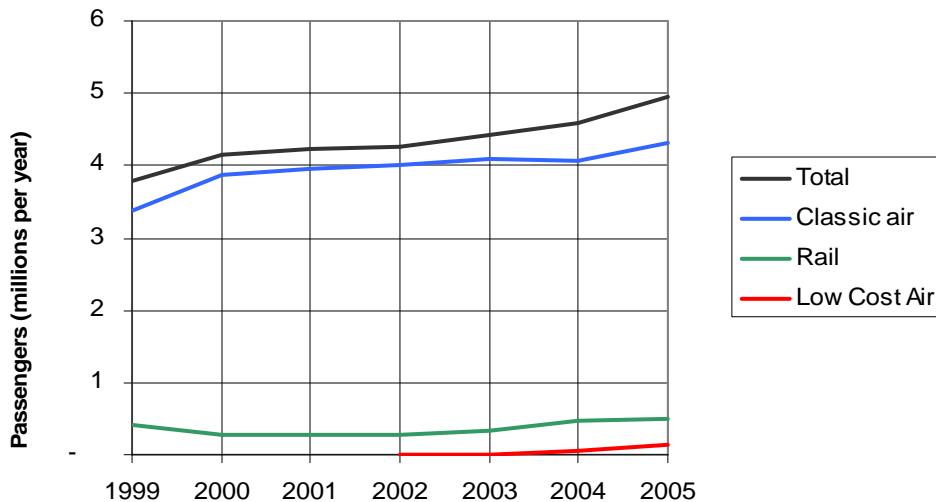

Source: AENA, RENFE press releases

- 4.19 A proportion of the air passengers on the route connect onto other air services at Madrid and therefore do not make point-to-point Madrid/Barcelona journeys. Connecting passengers comprise 12-15% of Iberia's traffic between Madrid and Barcelona and a lower proportion for other airlines. Rail is not currently an alternative for connecting passengers because there is no rail station at either airport. Taking this into account, the rail market share is slightly higher (around 13%).
- 4.20 There was a rise in rail market share between 2003 and 2004, when a high speed service was introduced on part of the route, reducing rail journey time between Madrid and Barcelona by 2 hours. However, this was not enough to have a noticeable impact on air traffic, and in our interview, Iberia confirmed that there was no visible impact on their demand from the opening of the first stage of the high speed line.

### Airline competition

- 4.21 Competition between classic and low cost carries on the Madrid-Barcelona route is currently very limited. Vueling is the only low-cost carrier and operates at a very low service frequency (currently only 2 flights per day).
- 4.22 The classic airline market is relatively competitive. The Spanish domestic market was liberalised in 1992, and incumbent competitors have since adopted a lot of the "low-cost" strategies. Low fares are available, particularly in comparison to domestic routes



in some other European countries that are dominated by classic carriers. However, slot constraints, particularly at Madrid airport, have limited the potential for other airlines to enter the market.

### Market characteristics

#### *Origins and destinations*

- 4.23 Madrid and Barcelona are both relatively densely populated: compared to cities in the UK or Germany, a high proportion of the population lives in the city centre. In principle, this means that the market should be appropriate for rail, as it is easier for rail to serve a densely populated city from one main station. However, compared to many other large European cities, the airports are also close to the city centres and are easily accessible by car and by public transport. A higher proportion of rail passengers travel to final destinations that are in Madrid or Barcelona's city centre (82%, 74%), compared to air (49%,59%).
- 4.24 The population distribution in Madrid and Barcelona, compared to the rail and air passenger distribution, is as follows. The high proportion of passengers ending up in locations away from Madrid can be due to the City's position as major transport hub. Overall, a higher proportion of rail passengers travel to city centres.

**TABLE 4.1 POPULATION V PASSENGER DISTRIBUTION IN MADRID AND BARCELONA**

Location	% of city population	% of rail passengers	% air passengers
<b>Madrid</b>			
City centre	61%	89%	78%
City region	39%	11%	22%
% passengers from outside of City	-	8%	37%
Location	% of city population	% of rail passengers	% air passengers
<b>Barcelona</b>			
City centre	45%	78%	65%
City region	55%	22%	35%
% passengers from outside of City	-	5%	8%

Source: ADIF OD Survey, Instituto Nacional de Estadística

#### *Types of passengers*

- 4.25 No reliable data is available for the proportion of air passengers that are travelling on business but we would expect this to be in line with the share of the Puente Aereo (70%). A majority of rail passengers using the Madrid-Barcelona service are business travellers (54%) but many of these are likely to be travelling to intermediate points, such as Zaragoza, for which rail is the fastest mode.

**Access times and costs**

- 4.26 Madrid Barajas Airport is located about 15 km away from the city centre, and is accessible by rail, bus, and car. Barcelona airport is also located close to the city centre, and is accessible by rail, bus, and car. The train terminals in both cities are located in the city centre.
- 4.27 The average access times from the city centre to terminal and their prices are as follows. The journey times are taken from passenger surveys and therefore reflect the total access time: the actual time in the metro from central Madrid (Nuevos Ministerios) to the airport is 12 minutes, and the time by train from Barcelona (Sants) to the airport is 15-20 minutes. Access cost by car refers to the car-parking charges at the terminal for 24 hours.

**TABLE 4.2 ACCESS TIMES AND COSTS, MAD-BCN**

Mode	Madrid Airport		Madrid Puerta de Atocha	
	Access time from City Centre (minutes)	Cost (€)	Access time from City Centre (minutes)	Cost(€)
Metro	33	1.00	n/a	n/a
Bus	40	1.00	n/a	n/a
Taxi	20	17-25	n/a	n/a
Car	28	15	n/a	19
Mode	Barcelona Airport		Barcelona Train Station	
	Access time from City Centre (minutes)	Cost (€)	Access time from City Centre (minutes)	Cost(€)
Train	37	2.20	n/a	n/a
Bus	28	1.05-03.45	n/a	n/a
Taxi	15-20	15-20	n/a	n/a
Car	15	15	n/a	21.6

Source: Madrid- Barcelona Origin- Destination Survey, AENA, Barcelona Airport

**Check-in times**

- 4.28 For the standard air services, Vueling and Air Europa Economy class passengers have to check in 30 minutes prior to departure, whereas Iberia and Spanair Economy class require that passengers check in 45-60 minutes before departure. Air passengers travelling on Business class have to check in at least 30 minutes prior to departure. Auto check-in is available on Iberia and Spanair and minimum auto check-in time is 30 minutes prior to departure. Iberia recently had to extend the check-in times for its services, as walking distances are much greater at the new Madrid airport terminal (terminal 4) than at the old terminals.
- 4.29 Passengers using the Iberia Puente Aereo service use separate check-in and security facilities, and the gate used is normally close by. This enables Iberia to offer an advance check-in of only 20 minutes for the Puente Aereo. Passengers do not make

reservations and therefore travel on a turn-up-and-go basis, which also facilitates a short advance check-in time.

- 4.30 Vueling is the first Spanish airline to offer its clients the option of reserving a seat online.
- 4.31 Compared to air passengers, rail passengers do not have to check in, and only have to show up at the train station shortly before the train's departure time. However, as a result of the perceived higher terrorist threat to high speed trains in Spain, all baggage is screened before passengers board the train, which means in practice that passengers must be at the platform entrance a few minutes before departure. This practice predates the March 2004 Madrid bombings.

## Prices and Revenues

### *Fare levels*

- 4.32 We have compared fares for a large number of journey combinations on the Madrid to Barcelona route in order to estimate average fares. We found that, on average, Vueling offered the lowest nominal fares of any of the airlines but that on average it was still marginally more expensive. Figure 4.5 shows our estimate of average fares for our sample of airlines.

**FIGURE 4.5 MADRID-BARCELONA AVERAGE SAMPLED FARES**

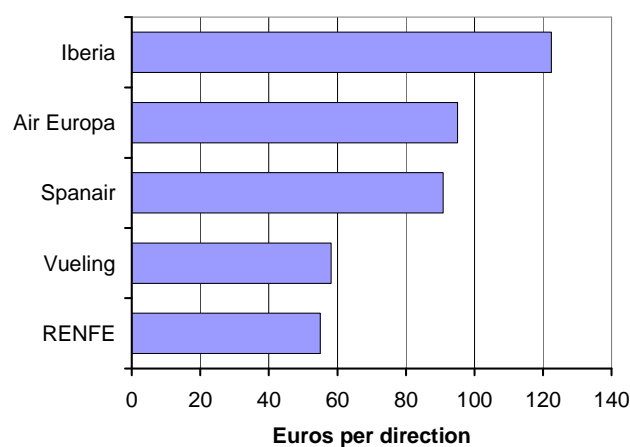

Source: Operator websites

- 4.33 However, although RENFE fares are cheaper on average, they are not necessarily cheaper for all passengers. There is wide variation in air fares depending on the nature of the journey (for example, single and return tickets), time and date of travel, and when tickets are purchased. In contrast, RENFE's return fares for the Madrid-Barcelona route are always €63 single or €100.80 return in second class (Turista), regardless of time of purchase, as unlike almost all other European long distance rail operators, Renfe does not use a yield management system to vary the price of tickets depending on demand. The lack of any such system may have impacted on rail market share, as in practice rail is often more expensive than air for travel at off-peak periods if the ticket is booked in advance. At peak periods it is not unusual for all seats for a

train to be reserved several days beforehand, meaning that potential passengers have to travel by air or by other forms of surface transport.

4.34 The following figure illustrates the prices of weekend return fares booked 2 months in advance and day return fares booked 24 hours in advance, reflecting typical leisure and business travel respectively. In all cases, prices include taxes and fees, and are for travel in economy class. Rail is a much cheaper option for travellers who purchase their tickets at the last minute but is more expensive for tickets booked in advance. As a higher proportion of potential train passengers are likely to be less time sensitive leisure passengers on this route, due to the relatively long journey time, rail is *more* expensive for what should be its main target market.

**FIGURE 4.6 EXAMPLE MADRID-BARCELONA FARES (ROUND-TRIP)**

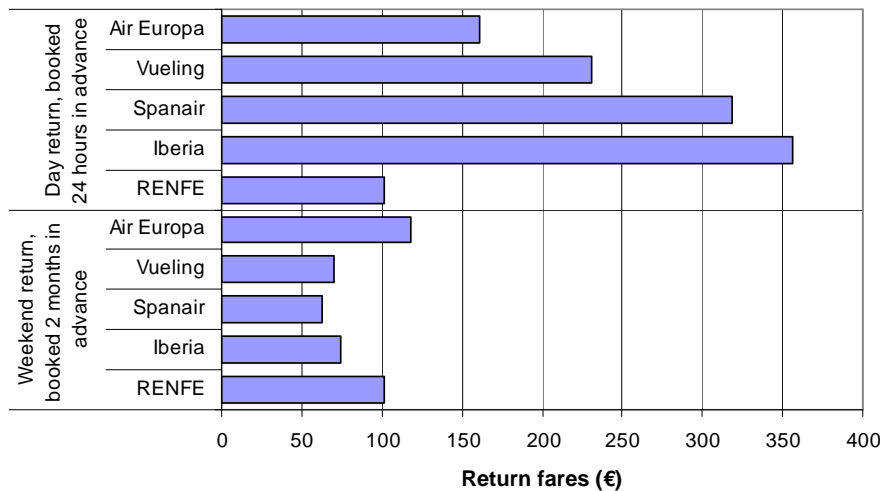

Source: Operators' websites

4.35 It should be noted that the majority (70%) of Iberia passengers between Madrid and Barcelona use the Puente Aereo. Tickets for this service are not restricted to any particular flight, and can be used at any time within one year of purchase on any air shuttle flight, availability permitting. There is therefore no variation in the price for Puente Aereo services. The fare is €348.8 (including taxes and fees) for an economy class return ticket and €400.8 for a business class ticket. The actual average Iberia fare is therefore higher than shown above – but most passengers still have the option of buying a cheaper ticket if they prefer.

Flexibility of tickets

4.36 Business class air tickets offer the greatest flexibility, and reservations can be changed or cancelled at any time at no cost. Economy class tickets on classic carriers can be changed up to two days prior to departure, at a €20 to €30 fee per change. Tickets are often non-refundable. Spanair, however, offers a “Change 12” option, whereby passengers can pay €12 at time of ticket purchase for the flexibility of changing the reservation up to the day before departure (instead of the usual €30 per change). Vueling tickets are also non-refundable; however, one can modify the reservation at €20, and change the passenger name at a charge of €30.

- 4.37 Rail tickets are relatively flexible. The train type, date, time and class of any train ticket can be changed up to 5 minutes prior to train's departure at a cost of 10% of paid fare. Cancellations, also possible up to 5 minutes prior to departure, are subject to a 15% charge.

#### Internet booking and e-tickets

- 4.38 All the operators on the route have a website through which tickets can be booked. Booking via the internet is free on Vueling and Spanair, whereas Iberia and Air Europa both charge €12 per internet booking. E -tickets are available on all of these airlines. However, travel agents still dominate air ticket sales in Spain, and Iberia confirmed that the majority of their tickets, even for domestic routes, are sold through travel agents, who receive a 1% commission.
- 4.39 Booking by phone usually results in a higher booking fee, except for Spanair, which does not charge an additional fee for phone bookings. Phone booking fees are €32 on Iberia, €15 on Air Europa, and £4 on Vueling. The high telephone booking fee is intended to push passengers towards internet booking, which allows airlines to recuperate the costs of running a website.
- 4.40 Purchase of long distance train tickets can be relatively difficult in Spain and this may have impacted on market share. As described below, there can be difficulties in purchasing via phone or internet and there are often very long queues for advance sales at ticket offices, sometimes with a waiting period of one hour or more. Tickets booked on the phone must be issued and collected at RENFE's sales offices and the passenger must turn up at least 2 hours in advance in order to do so. This is inconvenient for passengers and negates any benefit from buying the ticket over the phone. RENFE does allow internet purchase of fares but, for the first purchase, the customer must turn up in person at the ticket office in order to validate the credit card. Subsequent purchases can be made online and tickets can be printed at home. Train fares are the same when booked on the internet, by phone, or in person.
- 4.41 Passengers on Iberia and Spanair can check in on-line, or go through auto check-in at the terminal. Spanair Business Avant Class and Spanair Plus clients can also check in by telephone.

#### **Price trends**

- 4.42 Figure 4.7 shows revenue per passenger since 1996 for the Northeast services operated by the RENFE Grandes Líneas (Main Lines) business unit. The Madrid-Barcelona service is a substantial part of this service group but it should be noted that a significant proportion of the revenue per passenger may be determined by passengers travelling to intermediate stops. Nonetheless this is useful as an indicator of the overall trend in fares.
- 4.43 Fares increased substantially at the time of the opening of the first stage of the Madrid-Barcelona high speed line in 2003. In particular, the rail fare for Madrid-Barcelona journeys increased by nearly 50% at this time. Overall, rail fares on this route have increased faster than inflation. We do not have route-specific airline price data, but on average air fares have declined in real terms.

**FIGURE 4.7 RENFE GRANDES LÍNEAS NORTHEAST, REVENUE PER PASSENGER**

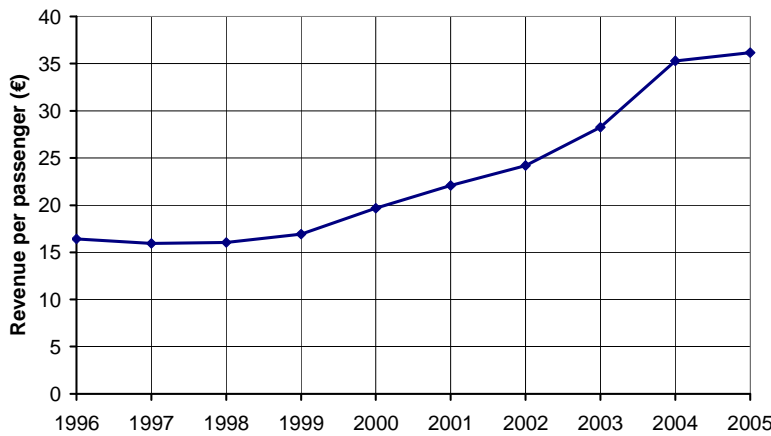

**Punctuality**

4.44 The following figure shows the punctuality of air and rail services in Spain. The punctuality statistics for airlines are based on the airline’s average, and are not specific to the Madrid-Barcelona route. Rail punctuality refers to that of the “Grandes Lineas” services, and is not specific to the Madrid-Barcelona service.

**FIGURE 4.8 PUNCTUALITY BY DIFFERENT MODES (2005)**

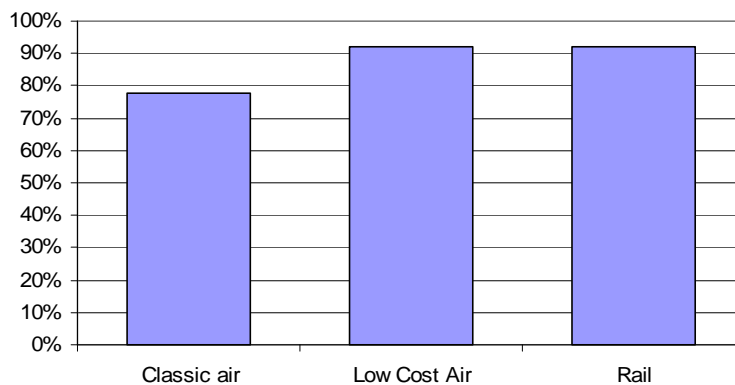

Source: RENFE, www.vueling.com, Association of European Airlines

**Service disruptions: Technical**

4.45 Rail services on the route are currently disrupted due to works to expand Barcelona Sants station for the additional volumes of traffic expected after the high speed line is completed. Journey times are being extended by 10-15 minutes and some trains are diverted.

**Service disruptions: Strikes**

4.46 There were a number of strikes on RENFE during 2004 and there have recently been more strikes. However, Spanish law requires that minimum services are provided during strike periods so that, compared to some other European countries, public

transport strikes do not have such a disproportionate impact on passengers. A significant proportion of trains still run during strikes.

#### **Air-rail links**

4.47 There are no direct connections between the rail service and the airports. At present, passengers connecting between airlines and railways must:

- At Madrid, use the metro with two changes, or use the suburban rail system plus one metro line (separate tickets must be purchased for each).
- In Barcelona, use a suburban rail line.

4.48 The new Madrid-Barcelona high speed line does not pass close to Madrid airport and therefore there is no possibility of a rail service to the airport in the medium term. Iberia informed us that they supported a high speed rail link to Madrid airport and that they believed that the train could substitute for aircraft on a number of domestic routes if there was a link to the airport. It believes that such a service would be attractive if there was through ticketing and baggage handling. It believes that the geography of Spain – with Madrid in the centre and few large towns between Madrid and the coasts – is ideal for a high speed link to the airport. As flights are scheduled in ‘wave’ patterns, it would not be necessary to have a high frequency rail service in order to substitute for domestic flights.

4.49 The Catalan government proposes to construct a high speed rail station at Barcelona airport. It is not yet clear whether any such station would be served by long distance high speed trains or only by regional shuttle services on the high speed line to other parts of Cataluña. However, as Barcelona airport is not the major base for any network airline, and is increasingly dominated by low cost carriers, the potential for through air-rail services appears to be limited.

4.50 Iberia, and some other Spanish airlines, did experiment with remote check-in at Nuevos Ministerios metro station in central Madrid. This was partly intended to facilitate passengers connecting with rail services, although only local and regional trains stop at this station. However, this service was not used by a significant number of passengers: Iberia did not have figures for its usage, but described it as well under 5% of passengers. This facility has subsequently been closed, as the Madrid metro does not as yet serve the new Madrid airport terminal, and therefore the metro is no longer attractive for accessing the airport.

#### **Service quality characteristics**

4.51 The service quality characteristics of the operators on this route are relatively similar. None of the operators provides facilities such as free catering in economy class, but all (including the rail operator and the low cost airline) pre-assign seats, and similar facilities are available at the terminals, including a lounge for business class passengers and free-of-charge toilet facilities. A comparison of the quality of on-board services by operator is provided in Table 3.4 below.

TABLE 4.3 SERVICE QUALITY CHARACTERISTICS

	Rail (Alitalia)	Classic airlines	Vueling
<b>On board service quality</b>			
Seat pitch (economy/standard class)	80+cm	78-80cm	78-80cm
Catering included (economy/standard class)	x	x	x
Check in baggage limit	Two bags that do not exceed 70x50x25cm in size	20kg (30kg in business class)	20kg
Pre-assigned seating	✓	✓	✓
Magazine available	✓	✓	not known
1st/business class available	✓	✓	x
Key differences in 1st/business class	Approx 30% more space Full meal service	Middle seat not allocated Snack service	N/A
Typical price surcharge for 1st/business class	50%	20-100%	N/A
<b>Airport / terminal facilities</b>			
Catering facilities	✓	✓	✓
Retail outlets	✓	✓	✓
Heated/secure waiting lounge	✓	✓	✓
Toilets	✓ (free)	✓ (free)	✓ (free)
Business lounge available	✓	Lounge available, but not needed for Puente Aereo – turn up and go	x
Business lounge open to all 1st class passengers	✓	✓	N/A

- 4.52 There is no free refreshment service provided on economy class travel by any of the air and rail operators. Both the airlines and RENFE provide food and drink for free in business/first class; on the airlines, this can be limited to a small snack reflecting the short journey time, but on the train, a full meal service is provided. Iberia was one of the first European major airlines to eliminate on-board catering. They told us that they subsequently undertook market research on whether this had any impact on routes where they were in competition with another carrier that still provided catering: they found that this had no impact on market share.

#### Terminals

- 4.53 The airports and rail stations on the route all have restaurants, cafés, banks, toilets, business lounges, car parks and access to public transportation. RENFE's station at Puerta de Atocha in Madrid is relatively poorly served by the city's metro network,



only being served by one line. However, the journey time by taxi to other parts of the city is usually low.

### **Taxes, subsidies and regulatory limits**

#### Taxes

- 4.54 VAT (IVA) is payable in Spain on all domestic rail and air tickets. In addition, a security tax of €1.37 is levied on air tickets in order to recover the costs of providing security services at the airports.
- 4.55 Airlines in Spain do not have to pay fuel tax. It is not transparent whether, or how much, rail operators pay in terms of fuel tax. As a major consumer of fuel in the country, RENFE is subject to preferential fuel prices under confidential agreements with electricity suppliers. The tax that RENFE pays on fuel is therefore dependent on the terms of the contracts.

#### Government subsidies

- 4.56 Airlines do not receive any government subsidy for operations on the Madrid-Barcelona route. In practice, the airlines operating the route cross-subsidise other Spanish air routes, through the system of airport charges. All airports in Spain are operated by AENA, which levies higher charges at the major airports than at the minor airports, even though the costs per passenger at the major airports are often lower. The result of this is that the users of Madrid and Barcelona airports cross-subsidise all other Spanish domestic air routes.
- 4.57 The Madrid-Barcelona rail service is operated by the RENFE Grandes Lineas (main lines) business unit. RENFE is a state-owned entity and receives state subsidy. There are two main types of subsidy:
- The infrastructure charges levied by ADIF, the infrastructure manager, do not fully recover its costs. It has received substantial direct support from the government, and up to two thirds of the construction costs of new lines have been paid for by the European Regional Development Fund.
  - Even though its infrastructure charges are subsidised, the Grandes Lineas business unit does not fully recover its costs from fares and therefore the remaining costs are covered by the government. In 2004, Grandes Lineas covered 87.5% of its costs.

#### Regulation of service levels and fares

- 4.58 Airlines on the Madrid-Barcelona route do not have any service level obligations and fares are not regulated.
- 4.59 RENFE is required to develop a business plan for each route, which must be agreed with the government before the service contract is signed. The contract is for a set level of service, and any changes must be approved by the Ministerio de Fomento. Rail fares are regulated in so far as the government must agree to any changes that RENFE proposes.

#### Other constraints

- 4.60 Madrid airport has, for a long time, suffered from the amongst the most extensive slot constraints of any major European airport, and this appears to be the main reason why there has been little competition from low cost airlines on this route to date. There are also slot constraints at Barcelona airport at some times of day although these are less severe. Vueling indicated that they cannot get enough slots at appropriate times of the day in order to compete with Iberia on the Madrid-Barcelona route: they told us that they could offer up to 8 services per day, making their service significantly more competitive, if appropriate slots were available.
- 4.61 There were limits to both terminal and runway capacity at Madrid airport. However, these limits are now in the process of being relieved:
- A new airport terminal (terminal 4) was opened in February 2006. This doubled the terminal capacity available and therefore alleviated the terminal capacity constraint.
  - Two new runways have been constructed, bringing the total to four.
- 4.62 As yet, no additional slots have been released at Madrid airport, due to limitations on air traffic control capacity. However, this issue is being addressed, and additional slots will be available from the winter timetable period 2006/7.

#### Future changes

##### Rail

- 4.63 Further to the completion of the research for this case study, RENFE has introduced new trains, branded Alvia, on this route. These trains pass through the gauge change at Lleida more quickly, as no change of engine or other manoeuvre is required. This has resulted in a reduction in journey times of 15 minutes; the best Madrid-Barcelona journey time is now 4 hours 15 minutes. Frequencies have also been increased marginally.
- 4.64 The new high speed line (AVE) between Madrid and Barcelona is expected to be completed in 2008, which will reduce rail journey time and enable a higher frequency service to be offered. It is expected that there may be up to 25 trains per day when this is complete. RENFE has ordered a large volume of high speed rolling stock for the line which in principle would be sufficient to operate up to three trains per hour in each direction, although in practice it is expected that some trains will be used on other routes.
- 4.65 As explained above, the Spanish government originally planned that the rail journey time for the Madrid-Barcelona route would be 2 hours 25 minutes when the high speed line was completed. This would have had a very significant impact on market share. RENFE believes that a journey time of under 2 hours 30 minutes is essential for the route to be competitive with air transport, given the high proportion of business traffic and the good location of Madrid and Barcelona airports.
- 4.66 However, the line was to be equipped with ERTMS, allowing operations of up to 350km/h. This does not currently work. RENFE expects that level 1 ERTMS

(allowing operations up to 250km/h) can be introduced, but are not clear when level 2 ERTMS (required for operations over 250km/h) will do so. The government is considering the installation of an alternative signalling system, equivalent to that used on the Madrid-Seville route, but this would be expensive and would be difficult to introduce whilst keeping the service running on the Madrid-Lleida route. The airlines operating on the route do not believe that the journey time of 2.5 hours will be achieved for the foreseeable future and are expecting a rail journey time of at least 3 hours.

4.67 Classic airlines expect to lose 30-40% of their traffic once the Madrid-Barcelona high speed rail line opens if the rail journey time is 3 hours or less. However, they expect that the impact of the high speed rail line on the route may be lower than on some other routes with equivalent journey times, due to:

- the good location of Madrid and Barcelona airports, which are both very close to the city centres; and
- the relatively high fares charged by RENFE.

4.68 RENFE also expects the market share that can be achieved by rail on the Madrid-Barcelona route will be lower than that achieved on the Madrid-Seville route, even if the journey time is 2 hours 30 minutes (which would be equivalent). It believes that rail should achieve a market share of about 50%. The lower expected share is due to the higher quality air service on the Madrid-Barcelona route.

Air

4.69 The recent opening of the new terminal and runways at Madrid Airport will lead to more slots being made available, from the winter 2006/7 timetable period. The existing operators expect that there will be an expansion of low cost airline services from Madrid when slots become available. This might include domestic routes, although incumbent operators believe that another reason why low cost airlines have avoided operating services on Spanish domestic routes is that they are expecting the expansion of the high speed train network.

4.70 easyJet already operates a number of routes from Madrid and there have been some reports that it will establish the airport as a base airport when slots become available. In March 2006, an easyJet spokesman confirmed that it was in discussions with AENA, the airport operator, to take over one of the existing terminals at Madrid airport from 2007. If this proceeds, it is possible that easyJet might launch services on the Madrid-Barcelona route. However, this is likely to depend on the timing of the opening of the Madrid-Barcelona high speed line, the journey time that can be achieved, and the fares that RENFE charges. None of these points are clear at present but are likely to become clearer in the next year.

4.71 Air journey times may increase in the future due to the saturation of air traffic control capacity at Madrid.

## Conclusions

- 4.72 The Madrid-Barcelona route is one of the largest air/rail routes in Europe. Rail transport currently has a market share of only 10%. In part, this reflects the long rail journey time, although another factor is that, if the ticket is purchased in advance and the passenger travels off-peak, air fares can be lower than rail fares. There is also a substantial market for bus travel between Madrid and Barcelona and at present this provides the low-cost alternative. The recent opening of the first part of the Madrid-Barcelona high speed line increased the number of rail passengers by 36%, despite substantial increases in fares, but this was not enough to have any noticeable impact on the number of air passengers.
- 4.73 Two of the Madrid/Barcelona airlines operate a turn-up-and-go ‘air bridge’ (Puente Aéreo) service. The service operated by the largest airline, Iberia, runs every 15 minutes at peak times and every 30 minutes throughout the day on weekdays. This air service between Madrid and Barcelona is unique within Europe and reflects the uniquely high volume of traffic: the Madrid/Barcelona airport pair has the highest level of traffic of any airport pairs in Europe. However, fares are relatively high. In part this reflects the high volume of price-insensitive business traffic, but it also reflects the fact that, largely due to slot constraints at Madrid airport, there has not been significant competition from low cost airlines to date.
- 4.74 When the high speed line between Madrid and Barcelona is completed, there is the potential for substantial transfer of traffic from air to rail. However, the extent of the transfer will depend on the journey time that is achieved. It currently appears unlikely that the planned journey time of less than 2 hours 30 minutes will be achieved when the line is completed, due to problems with the signalling system, ERTMS. A journey time that is greater than this may be too high to be competitive for time-sensitive business passengers, particularly given the good locations of Madrid and Barcelona airports relative to the city centres.

## 5. MADRID - SEVILLE

### Introduction

- 5.1 The Madrid-Seville route was the first high speed line to be opened in Spain. The AVE (Alta Velocidad España) service linking Madrid and Seville was opened for the Seville Expo in 1992 and has provided a frequent service between the cities since then. RENFE, the Spanish national rail operator, operates the rail service between Madrid and Seville as part of its Alta Velocidad (High Speed) business unit. Unusually in Europe, the service operates entirely on new infrastructure: the conventional rail network in Spain uses a broader track gauge than the rest of Europe but the Spanish high speed lines have been built to standard European gauge.
- 5.2 There is currently no low-cost air carrier operating between Madrid and Seville. Iberia is the only airline offering scheduled services between the cities, and its services are relatively low frequency, reflecting the high quality alternative rail service.

### Journey times and frequencies

#### Journey times

- 5.3 A high-speed rail service has been in operation between Madrid and Seville since 1992. For the past decade, the average journey time has remained constant at approximately 2 hours 30 minutes, although trains can achieve slightly faster journey times if they run non-stop (most trains stop at Córdoba). Scheduled air journey time is 1 hour.
- 5.4 In addition, some other trains ('Talgo 200') use the high speed line between Madrid and Seville. The main purpose of these trains is to provide through links to cities beyond the high speed line. These trains use special gauge-convertible rolling stock which can run on both the standard gauge high speed line and the broad gauge conventional rail network. These trains are limited to a maximum speed of 200km/h on the high speed line, and as a result, the journey time is around 30 minutes longer. Slightly lower fares are offered for Madrid-Seville journeys on these trains.

#### Frequency and available seats

- 5.5 On weekdays there are currently 23 high-speed rail services and 7 classic air services per day on the route. There are no low cost airlines operating on the route. The number of rail services operated on this route has increased year-on-year since 1995 when there were only 16 per day in operation. This was in itself much greater than the number of trains operated prior to the opening of the high speed line (5 per day).
- 5.6 Iberia is the only airline offering scheduled services between the cities, and apart from a brief period around 2001 when Spanair also operated a service, this has been the case throughout the last ten years. Trends in frequencies are summarised in Figure 5.1.

**FIGURE 5.1 RAIL AND AIR FREQUENCY (EACH WAY)**

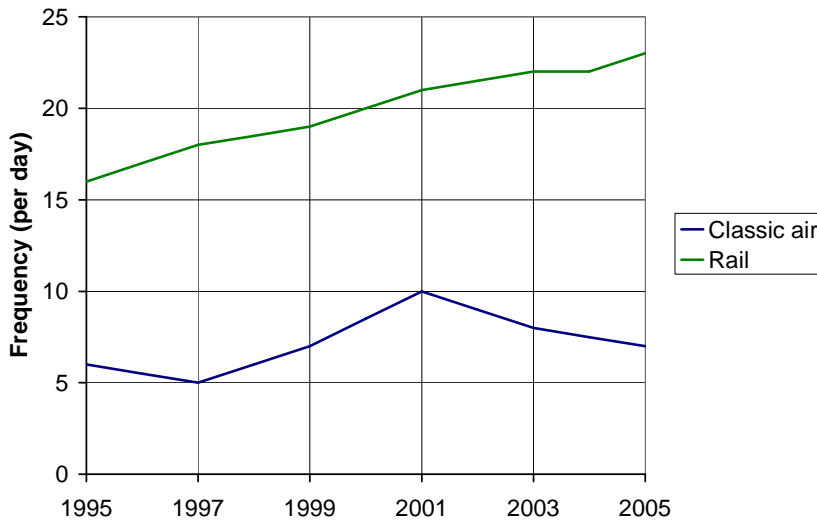

Source: Thomas Cook European Rail Timetable, OAG airline guide

5.7 The high speed trains operated between Madrid and Seville have a seating capacity of about 320. Average aircraft size is approximately 130, nearly 25% less than in 1995. Consequently, rail’s dominance of the market in frequency terms is increased when seating capacity is considered. This is illustrated in Figure 5.2.

**FIGURE 5.2 RAIL AND AIR AVAILABLE SEATS (TOTAL PER YEAR)**

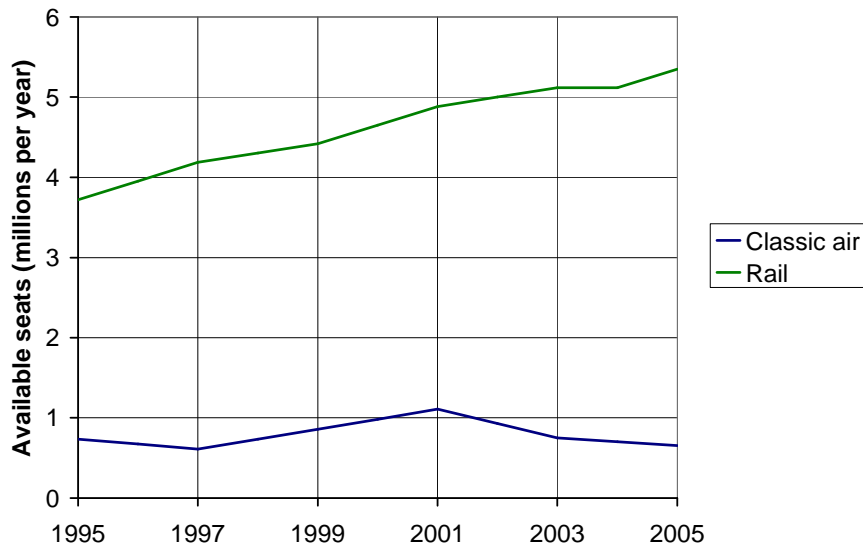

Source: Thomas Cook European Rail Timetable, OAG airline guide

5.8 Not all of the rail capacity is used by passengers travelling between Madrid and Seville: some passengers will embark and disembark at the intermediate stops which are on the route. However, the trains on this route make few intermediate stops (usually just at Córdoba) and therefore most of the capacity is used for Madrid-Seville passengers.

- 5.9 RENFE runs a large number of additional trains at peak periods, and many trains between Thursday and Sunday use double-length units. We understand that the demand for the service varies substantially between peak and off-peak periods, in part because RENFE does not use a yield management system to ‘smooth’ demand.

#### Bus competition

- 5.10 Historically, buses rather than trains have provided the main mode of long distance public transport in Spain. Total bus passenger kilometres within Spain are 2.5 times rail passenger kilometres – in contrast to other countries such as France, where the number of rail passenger kilometres is nearly twice the number of bus. This is because on many routes within Spain, bus journey times are equivalent to or better than rail journey times, and unlike many European countries, Spain does not impose regulatory limits on bus competition with rail.
- 5.11 Bus journey times between Madrid and Seville are significantly longer than rail journey times but fares are substantially lower. The journey time by bus is 6 hours compared to 2 hours 30 minutes by train, but the standard one-way fare by bus is €17, compared to €70 by train.
- 5.12 There are 11 scheduled buses each way per day between Madrid and Seville, and multiple buses often run on Spanish domestic routes at times of high demand. As explained below, prior to the opening of the high speed line, more passengers travelled by bus than by train on the Madrid-Seville route; buses still carry approximately one fifth of the number of passengers carried by the train on this route.

#### Market share

- 5.13 Airlines in Spain have cut capacity on Madrid-Seville due to competition from high speed rail services. When the high speed train service started operation in 1992, Iberia lost about 35% of its traffic to rail. Iberia currently provides six services per day between Madrid and Seville, which it believes it is the minimum viable service to feed its hub at Madrid. A low cost carrier indicated that they would not enter a market such as Madrid-Seville due to intense competition from a good high speed rail service.
- 5.14 Figures are available for the number of air passengers on the route since 1999. The total market for air and rail travel between Madrid and Seville grew by 28% during this period, with rail accounting for most of the growth; the volume of air travel has been approximately unchanged in this period.

**FIGURE 5.3 RAIL AND AIR PASSENGERS**

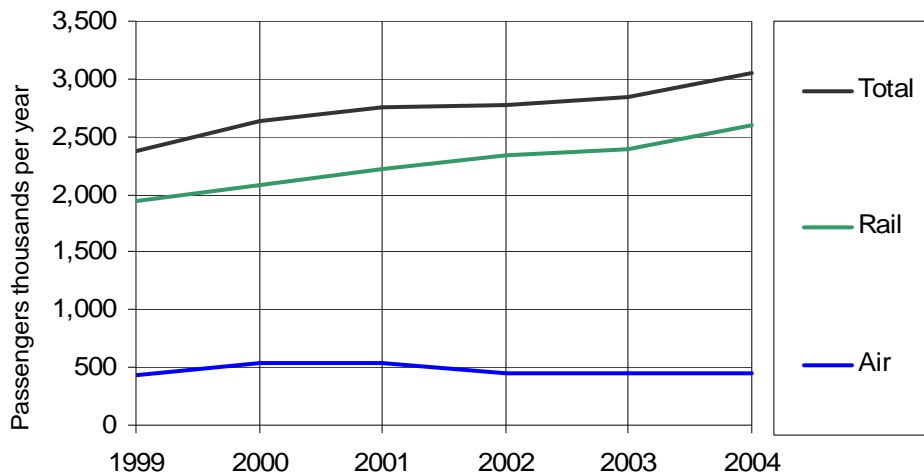

Source: Data from AENA and Ministerio de Fomento; SDG analysis

5.15 At present, rail has a market share of 84% on this route. In addition, around 60% of air passengers travelling between Madrid and Seville are doing so in order to connect on to other air services at Madrid; as explained below, rail is not currently a viable alternative for these passengers, because the link between the rail station at Madrid and the airport is poor. This implies that rail captures around 94% of all point-to-point trips between Madrid and Seville.

5.16 The opening of the Madrid-Seville high speed line substantially changed the nature of inter-modal competition in this corridor. Previously, the majority of point-to-point passengers travelled by car, and more passengers travelled by bus than by train. The opening of the high speed line led to substantial transfers from both car and air transport. The rail share of the whole air/rail market (including connecting air passengers) increased from 21% in 1991 to 82% in 1993. The rail market share has remained approximately unchanged ever since.

**FIGURE 5.4 IMPACT OF THE OPENING OF THE AVE ON MARKET SHARE**

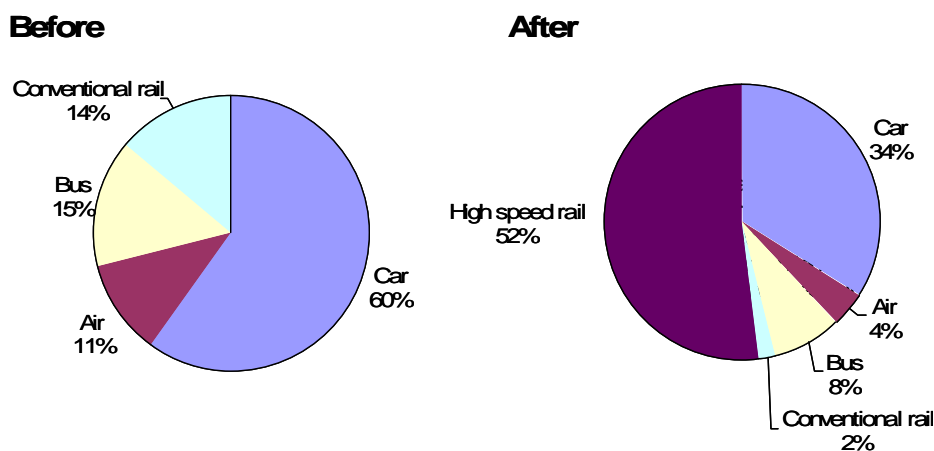

Source: RENFE



## Access to Services

- 5.17 Madrid Barajas Airport is located about 15km away from the city centre, and is accessible by metro, bus, and car. Seville Airport is located 7km outside of the city. There is no rail service to Seville Airport, but it is accessible by bus and car. The train terminals in both cities are located in the city centre.
- 5.18 The average access time from the city centre to terminal and their prices are as follows. Access cost by car refers to the car-parking charges for the terminal for 24 hours.

**TABLE 5.1 ACCESS TIMES AND COSTS, MAD-SVQ**

Mode	Madrid Airport		Madrid Puerta de Atocha station	
	Access time from City Centre (minutes)	Cost (€)	Access time from City Centre (minutes)	Cost (€)
Underground	15-30	1.00	n/a	n/a
Bus	30-40	1.00	n/a	n/a
Taxi	20-30	17-25	n/a	n/a
Car	28	15	n/a	19/day

Mode	Seville Airport		Seville Santa Justa station	
	Access time from City Centre (minutes)	Cost (€)	Access time from City Centre (minutes)	Cost(€)
Train	n/a	n/a	n/a	n/a
Bus	30	2.30	n/a	n/a
Taxi	15	17-21	n/a	n/a
Car	15	12	n/a	24

Source: Madrid- Barcelona Origin- Destination Survey, AENA

- 5.19 Air passengers travelling in business class have to check in at least 30 minutes period to departure. Economy class requires that passengers check in 45-60 minutes before departure. Auto check-in is also available on Iberia and minimum auto check-in time is 30 minutes prior to departure.
- 5.20 RENFE does not require passengers to check in but it does require passengers to arrive at the station five minutes in advance, as it screens passengers' baggage prior to joining the train. This is unusual compared to other high speed rail services and reflects the historically higher perceived threats to security in Spain.

## Prices and Revenues

- 5.21 We have compared fares on the Madrid to Seville route for various journey combinations in order to estimate average fares and understand the pricing system. There are two important issues:
- the average level of fares; and

- the variability and availability of fares.

5.22 We found that average air fares were higher than average rail fares on this route. We collected a sample of fares levied by both operators and found that the average rail fare was around €60 per direction, compared to around €140 for Iberia.

5.23 Figure 5.5 below shows return fares for two specific types of journeys – a day return booked 24 hours in advance (typical of a business passenger) and a weekend return fare booked 2 months in advance (typical of a leisure passenger). Air travel is much more expensive for the business trip booked at the last minute. However, air and rail prices are similar for typical leisure trips.

**FIGURE 5.5 EXAMPLE MADRID-SEVILLE FARES (ROUND-TRIP)**

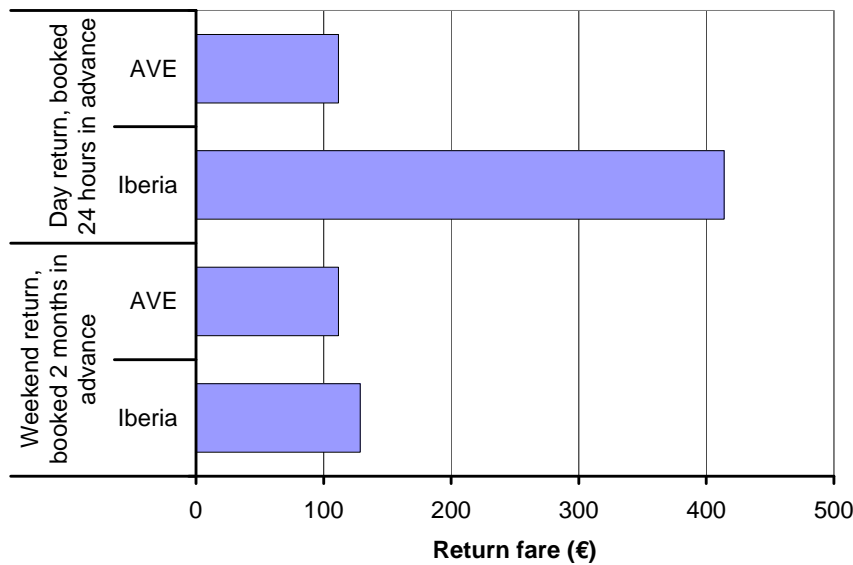

Source: Operators' websites

5.24 The prices shown above are for economy/standard class travel. Iberia's business class tickets offer the greatest flexibility, and reservations can be changed or cancelled at any time. Economy class tickets can be changed up to two days prior to departure, at €20 per change. Tickets are refundable if cancelled up to two days before departure, at a cancellation fee of €24. The train type, date, time and class of any train ticket can be changed up to 5 minutes prior to train's departure at a cost of 10% of paid fare. Cancellations, also possible up to 5 minutes prior to departure, are subject to a 15% charge.

5.25 There is wide variation in air fares depending on travel options (for example, single and return tickets) and when tickets are purchased. A ticket purchased two months in advance can be half the price of that purchased only 24 hours before departure. In contrast, AVE Madrid-Seville (rail) fares are almost always €69.80 single or €111.70 return, regardless of time of purchase, and can be booked 60 days prior to date of travel. There are three 'off-peak' AVE trains per day with marginally lower fares (€63 one-way) and lower fares are also available for travel on the twice-daily slower Talgo 200 trains (€54.70 one way).

- 5.26 The basically fixed nature of AVE fares reflects the fact that, unlike almost all other European long distance rail operators, RENFE does not use a yield management system to vary the price of tickets depending on demand. The lack of any such system may have had some impact on rail market share, as rail can be more expensive than air for travel at off-peak periods if the ticket is booked in advance. At peak periods it is not unusual for all tourist class seats on a train to be reserved several days beforehand, meaning that potential passengers have to buy a more expensive first/club class rail ticket, or travel by other forms of transport. A further consequence of the lack of a yield management system is that demand is not smoothed over time, and as a result, RENFE has to provide substantially greater capacity at peak periods in order to accommodate demand. RENFE told us that they are planning to introduce a yield management system in the future.
- 5.27 Both Iberia and RENFE have websites through which tickets can be booked. Iberia charges €12 per internet booking, compared to 3€ per phone booking. The fares shown above include the internet booking charge. The high telephone booking fee is intended to switch passengers towards internet booking, which allows airlines to recuperate the costs of running a website. E-tickets are available.
- 5.28 Passengers can also check in on-line, or go through Iberia's auto check-in at the terminal. The majority of Iberia tickets are still sold through travel agents, who receive a 1% commission. However, the proportion of tickets booked by internet is increasing.
- 5.29 Train fares are the same when booked on the internet, by phone, or in person. Tickets booked on the phone, however, must be issued and collected at RENFE's sales offices. We discuss the issue of booking rail tickets in Spain in more detail in the case study for the Madrid-Barcelona route.
- 5.30 Figure 4.7 below shows the revenue per passenger for the RENFE Madrid-Seville service. Note that this figure includes revenue for passengers travelling to intermediate stops (primarily Córdoba) but does not include revenue for other services operated by the Alta Velocidad business unit, such as the Talgo 200, and is therefore reasonably representative. Revenue per passenger has increased since 1996, but the increase has been broadly in line with inflation. We do not have route-specific revenue data for Iberia, but in general air fares have fallen, in real terms, over this period.

**FIGURE 5.6 RENFE MADRID-SEVILLE REVENUE PER PASSENGER**

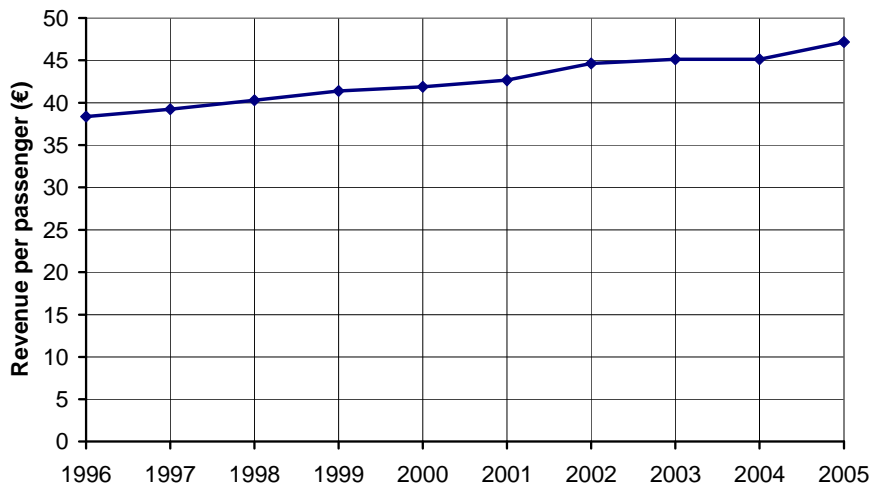

Source: Ministerio de Fomento

**Punctuality**

5.31 The punctuality achieved by the high speed train is much better than that achieved by the air service. Figure 5.7 shows the punctuality of Iberia and AVE services in 2005. According to RENFE, AVE achieved a punctuality index of 98.5% in 2005, meaning 98.5% of the train services arrive within 3 minutes of their scheduled arrival times. The figure for air punctuality is shown against a much less demanding target (15 minutes delay).

**FIGURE 5.7 PUNCTUALITY OF AIR AND RAIL SERVICES (2005)**

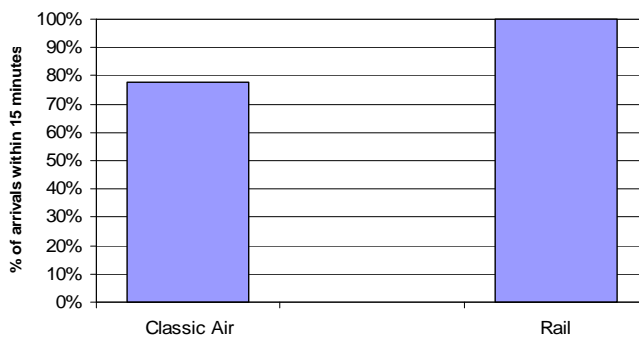

Source: RENFE, Association of European Airlines

5.32 The Madrid-Seville rail service is exceptionally punctual in comparison to almost any other European rail service. Reflecting this high level of punctuality, RENFE offers a punctuality promise (Compromiso de Puntualidad): the entire cost of the ticket is refunded to passengers if a train is more than 5 minutes late, provided that it is responsible for the delay. Less than 0.3% of tickets have to be refunded. RENFE believes that the punctuality of the AVE is, along with the journey time, the most important reason for its high market share.

- 5.33 There are four main reasons for the high level of reliability:
- All parties are incentivised to maintain reliability, because the organisation responsible for the delays (the train maintenance company, the operator or the infrastructure company) have to pay for the passenger refunds.
  - The route uses entirely new high speed infrastructure. All other European high speed rail services use conventional infrastructure for at least part of the journey (usually the approach to major cities).
  - Only a small proportion of the capacity on the Madrid-Seville high speed line is used. This means that delays to one train are much less likely to cause delays to subsequent trains.
  - The timetable is relatively generous. Trains are scheduled to take 2 hours 30 minutes for a journey of 471km (an average of 188km/h) despite there being a maximum operating speed of 300km/h. There is therefore scope to recover from any delays.

#### Service disruptions - strikes

- 5.34 There were a number of strikes on RENFE during 2004 and there have been further strikes during 2006. However, Spanish law requires that minimum services are provided during strike periods so that, compared to some other European countries, public transport strikes do not have such a disproportionate impact on passengers. A significant proportion of trains still run during strikes.

#### Air-rail links

- 5.35 There are no direct connections between the rail service and the airports. At present, passengers connecting between airlines and railways must:

- At Madrid, use the metro with two changes, or use the suburban rail system plus one metro line (separate tickets are required); and
- In Seville, use the suburban rail services.

- 5.36 Iberia, and some other Spanish airlines, did experiment with a remote check-in at Nuevos Ministerios metro station in central Madrid. This was partly intended to facilitate passengers connecting with rail services, although only local and regional trains stop at this station. However, this service was not used by a significant number of passengers: Iberia did not have figures for its usage, but described it as well under 5% of passengers. This facility has subsequently been closed, as the Madrid metro does not as yet serve the new Madrid airport terminal, and therefore the metro is no longer attractive for accessing the airport.

- 5.37 RENFE does offer a 25% discount to passengers making onward journeys by air.

#### Service quality

- 5.38 The service quality provided on-board in economy/tourist class by the airline and rail operator are similar. The premium class service provided by RENFE is better, reflecting the longer in-vehicle journey time, but it perceives that this is much less important than either journey time or reliability in determining the high market share

achieved by the train. A comparison of the on-board services by operator is provided in the table below.

**TABLE 5.2 SERVICE QUALITY CHARACTERISTICS**

	Rail (AVE)	Iberia
<b>On board service quality</b>		
Seat pitch (economy/standard class)	80+cm	78-80cm
Catering included (economy/standard class)	x	x
Check in baggage limit	Two bags that do not exceed 70x50x25cm in size	20kg (30kg in business class)
Pre-assigned seating	✓	✓
Magazine available	✓	✓
1st/business class available	✓	✓
Key differences in 1st/business class	Approx 30% more space Full meal service	Middle seat not allocated Snack service
Typical price surcharge for 1st/business class	€30-50	€25-100
<b>Airport / terminal facilities</b>		
Catering facilities	✓	✓
Retail outlets	✓	✓
Heated/secure waiting lounge	✓	✓
Toilets	✓ (free)	✓ (free)
Business lounge available	✓	Lounge available, but not needed for Puente Aereo – turn up and go
Business lounge open to all 1st class passengers	✓	✓

- 5.39 Two levels of first class service, Preferente and Club, are available on the train. These are similar but a more extensive choice of meals and drinks is provided in Club.

#### Terminals

- 5.40 The airports and rail stations on the route all have restaurants, cafes, banks, toilets, business lounges, car parks and access to public transportation.
- 5.41 RENFE's station at Puerta de Atocha in Madrid is badly served by the city's metro network compared to main rail stations in some other European cities, only being served by one metro line. However, the station is centrally located and journey time by bus or taxi to other parts of the city is usually low.

---

## Taxes, subsidies and regulatory limits

### Taxes and fees

- 5.42 VAT (IVA) is payable in Spain on all domestic rail and air tickets. In addition, a security tax of €1.37 is levied on air tickets in order to recover the costs of providing security services at the airports.
- 5.43 Airlines in Spain do not have to pay fuel tax. It is not transparent whether, or how much, rail operators pay in terms of fuel tax. As a major consumer of fuel in the country, RENFE is subject to preferential fuel prices under confidential agreements with electricity suppliers. The tax that RENFE pays on fuel is therefore dependent on the terms of the contracts.

### Government Subsidies

- 5.44 Iberia does not receive any subsidy for the operation of the Madrid-Seville service. Indeed, as discussed in the Madrid-Barcelona case study, airlines using major airports in Spain (such as Madrid) cross-subsidise airlines using secondary airports.
- 5.45 In January 2005, the railway system in Spain was restructured, whereby the infrastructure and operational branches of RENFE were split into two separate companies, ADIF (infrastructure) and RENFE Operadora (operations). RENFE Operadora receives no direct public service obligation funding for the operation of the AVE service, but it appears not to pay for the full cost of infrastructure maintenance. It also does not pay for the capital costs of the high speed lines.
- 5.46 A significant proportion of the costs of ADIF are covered by grants from the Spanish government, although it is not possible to attribute the subsidies received by ADIF to the infrastructure charges on any individual line. The infrastructure charges also do not cover the capital costs incurred in construction of the high speed lines: a significant proportion of these costs were paid for by the European Regional Development Fund and matching funds from the Spanish government. In addition, we understand that some of the rolling stock used by RENFE, acquired at the time of the construction of the Madrid-Seville line, may have been purchased by the government on its behalf, and therefore we are not clear that the capital costs of rolling stock are included. Subsequent purchases of rolling stock have been made by RENFE and are included in its costs.

### Service obligation

- 5.47 Airlines on the Madrid-Seville route do not have any service level obligations.
- 5.48 RENFE Operadora's high speed service branch is required to develop a business plan for each route, which must be agreed with the government before the service contract is signed. The contract is for a set level of service, and any changes must be approved by the Ministerio de Fomento.

Fare regulation

- 5.49 Air fares are not regulated. Rail fares are regulated in so far as the government must agree to any changes that RENFE proposes.

Slot constraints

- 5.50 Madrid airport has, for a long time, suffered from amongst the most extensive slot constraints of any major European airport, and this is one of the reasons why there has been little competition from low cost airlines on this route to date. However, during 2006 a new terminal and two new runways have opened at Madrid, and the number of slots will be increased from October. This should alleviate the constraints for the foreseeable future. Seville airport is not slot-constrained.

**Future changes**

- 5.51 There are no significant changes planned by any of the operators for the Madrid-Seville service. The rail service is already high speed throughout and therefore there is no obvious scope for this to be improved. RENFE has recently ordered a large number of additional high speed trains and it is therefore possible that it may increase frequencies on the route. The opening of the high speed route between Córdoba and Málaga, expected in 2008 will result in substantially improved frequencies on the high speed line between Córdoba and Madrid, although no change in frequencies to Seville.
- 5.52 In addition, the availability of new capacity at Madrid airport from October 2006 will create the potential for other airlines to enter the Madrid-Seville market.

**Potential for low cost competition**

- 5.53 There are few other European routes where low cost airlines seek to compete with rail services with a journey time of less than 3 hours. To date, the slot constraints at Madrid airport have also limited the potential for competition. However, these constraints will be relieved from October 2006.
- 5.54 In our view there might be potential for a low cost carrier to provide services between Madrid and Seville in the future, as:
- Rail fares are relatively high and, as yet, the operator does not apply a yield management system. The result of this is that, for journeys planned well in advance, rail travel can already be more expensive than air travel; for journeys planned at the last minute, trains can be fully booked.
  - Airport charges are relatively low in Spain.
  - Both Madrid and Seville airports are easily accessible from the city centres.
- 5.55 However, given the high quality of the rail service and the fact that tourist class rail fares do not currently exceed €70 one way, the potential market share that could be achieved by a low cost air service is probably quite low. In addition, the planned introduction of a yield management system by RENFE should address some of the present weaknesses in the pricing of the service.



## Conclusions

- 5.56 The introduction of the AVE service between Madrid and Seville transformed the market. Previously, the rail journey time was 6-7 hours and there were only a handful of trains per day; buses carried more passengers than trains on the route. The AVE service has now achieved a share of 84% of the total market and a share of over 90% of the point-to-point market. This is mostly as a result of the fast journey time, but the share is higher than has been achieved by rail on other routes with similar journey times. This reflects the high standard of reliability offered, the fact that the AVE trains are comfortable and offer good on-board services, and that there is no need for passengers to check in more than 5 minutes in advance.
- 5.57 However, although on average fares for the AVE are not out of line with other European high speed rail services, uniquely RENFE does not use a yield management system to match demand to supply at peak and off-peak times. This means that the AVE offers very attractive fares for business travellers that book at the last minute, but also means that it is often fully booked well in advance during busy periods, so they cannot always travel at their chosen time. In addition, this means that it is not possible for very price-sensitive passengers to travel by train, even by booking in advance and travelling at off-peak times. This may have contributed to the fact that there is still a substantial market for bus travel between the cities.
- 5.58 RENFE perceives that the main reasons that the rail service has achieved such high market share are the relative speed of the service and the high punctuality. It believes that the market share has been achieved despite the price and acknowledges that, given this, low cost air competition could have an impact on market share in the future. It believes that, whilst the on-board service quality offered on the AVE is better than that offered by the airline, this is much less important in determining market share.

## 6. ROME – MILAN

### Introduction

- 6.1 The Rome to Milan route is characterised by high levels of traffic both on the rail and air markets, but both the rail operator and the airlines are subject to competition from road transport. The rail service is currently operated by normal speed Intercity services which stop in each provincial capital along the route, as well as by high speed Eurostar Italia services that connect Rome and Milan and also stop in Florence and Bologna; however, these trains only run on high speed lines for part of the route and even here are currently constrained to 250km/h. High speed rail in Italy started in 1978 with the opening of the first high speed line between Rome and Florence. Since then the infrastructure work has expanded and new rolling stock has come on stream, the current generation of high speed trains includes trains that range in age from 2 to 30 years. The trains are owned and operated by Trenitalia on this route.
- 6.2 Since December 2004, Trenitalia has also operated a ‘low-cost’ Eurostar service on the route, using the brand TrenOK. This service runs once a day and is operated by first generation tilting Eurostar trains, offering second class service only. The journey time is equivalent but it uses secondary stations in Rome and Milan. If booked in advance and subject to ticket restrictions, a one way ticket is €37 cheaper than an equivalent second class ticket on the standard Eurostar service. Following this, Trenitalia introduced in November 2005 an additional Eurostar service, TBiz, aimed at business class passengers with two trains in each direction per day. TBiz has a higher level of service but a 20% higher price.
- 6.3 Eurostar faces competition from airlines operating between the main Rome and Milan airports. The majority of services operate between Milan Linate and Rome Fiumicino between Monday and Friday, while on weekends the route from Milan Malpensa to Rome Fiumicino has more services. In addition to this, there are also services from Bergamo (Orio al Serio) to Rome Fiumicino: this airport is a similar distance from the centre of Milan as Malpensa.
- 6.4 There were no genuine low-cost airlines operating on this route at the time we undertook our research, but as of the end of March, Ryanair started a service between Orio al Serio airport and Ciampino airport. In addition, the airlines Meridiana and Blue Panorama now market their services as low cost. The other airlines operating on the route are Alitalia and Air One.

### Service provision

#### Journey times

- 6.5 The current journey time for the Eurostar service between Rome and Milan is 4 hours 30 minutes, and the TBiz train completes the journey in 4 hours 5 minutes (although to Rome Tiburtina station: the journey time to the better-located Termini is still 4 hours 15). In the future, new high-speed infrastructure and upgrading of the existing high speed link to 300km/h will reduce the journey times by a total of 86 minutes, to around 3 hours. The table below sets out the current and future journey times for the high-speed rail network between Rome and Milan.

**TABLE 6.1 EUROSTAR CURRENT AND FUTURE JOURNEY TIMES**

Section	Current distance (km)	Current journey times	Journey times on new lines
Milan-Bologna	215	1h 42min	1h
Bologna-Florence	92	59min	30min
Florence-Rome	254	1h 35min	1h 20min

Source: Trenitalia

- 6.6 In the past 10 years, there have not been any significant changes in journey times; the last significant change came with the upgrading of the Rome to Florence route. Since 1995, the journey times on the route have improved mainly as a result of operational changes, new rolling stock and minor upgrades, bringing the total journey times down from 4 hours and 55 minutes to 4 hours and 30 minutes.
- 6.7 As of mid December 2005, Italy's first real high speed line (300 km/h) opened to passenger service between Rome and Naples (outside of the case study route). This saw an improvement in journey times of 40 minutes. Apart from upgraded trains, the service offered is equivalent to that of the current Eurostar service.
- 6.8 The air journey time between Milan and Rome is scheduled to be approximately 1 hour 20 minutes for the route between Milan Malpensa and Rome Fiumicino, approximately 1 hour 10 minutes between Milan Linate and Rome Fiumicino and approximately 1 hour 15 for the route Bergamo Orio al Serio and Rome Fiumicino. In practice, the flight time is shorter than this, but both the Milan and Rome airports are congested and aircraft often need to wait for permission to take off and land.

#### Frequency and available seats

- 6.9 If we define Blue Panorama and Meridiana as low cost airlines, there are currently 34-35 classic air services and 2 low cost air services between Milan Linate and Rome Fiumicino; 27 classic air services and 3 low cost air services between Milan Malpensa and Rome Fiumicino; and 2 classic air services between Bergamo Orio al Serio and Rome Fiumicino. After we undertook the research for this study, Ryanair entered the market with a twice-daily service from Bergamo to Rome Ciampino. There are also 17 daily direct trains between Milan and Rome. This does not include the slower InterCity and 'Espresso' branded trains between Rome and Milan as these take respectively 1.5 and 3.5 hours longer than the Eurostar trains, as well as stopping at more stations and having a longer dwell time at these stations. These trains provide a lower cost alternative to the Eurostar service
- 6.10 For Alitalia, the number of flights per week has fluctuated in recent years but has now returned to the level of 1997 on the main Fiumicino to Linate route, while the initial peak in the Malpensa frequencies (around the time of the opening of the new terminal) has now fallen away and is approaching previous levels of traffic. The flights passing through Orio al Serio stopped for a significant period of time but have recently recommenced. These trends are shown in Figure 6.1 below.

FIGURE 6.1 RAIL AND AIR FREQUENCY (EACH WAY PER WEEK)

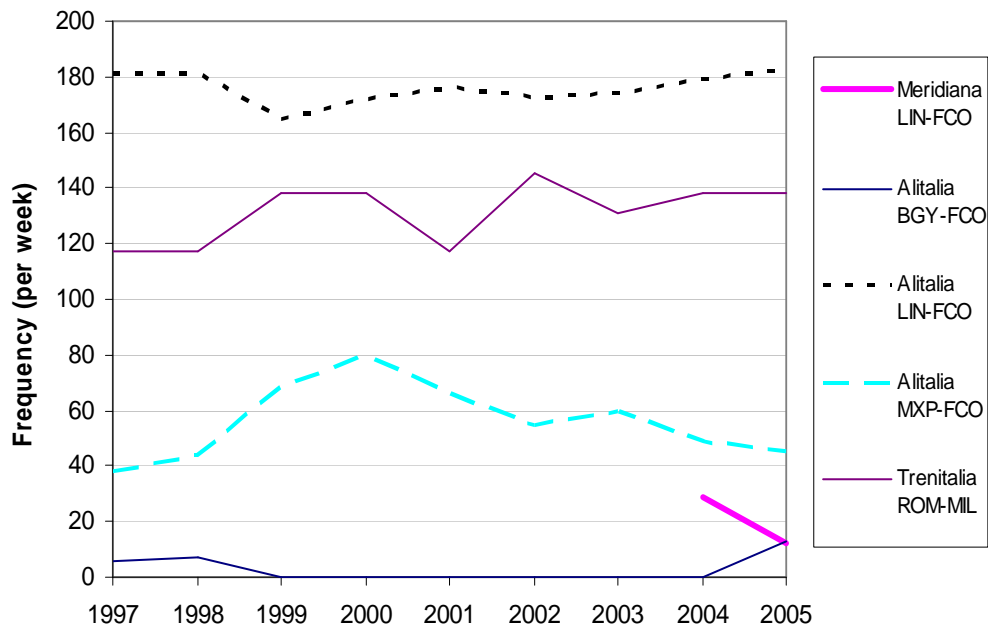

Source: Alitalia, Meridiana, Trenitalia

- 6.11 Eurostar trains have considerably more seats than aircraft. On average, aircraft operating on the Rome-Milan route have 160 seats. The number of seats available for Alitalia decreased from 2003 to 2004 on this route and would have continued to do so in 2005 if it wasn't for the fact that Alitalia in 2005 restarted serving the route between Orio al Serio and Fiumicino.
- 6.12 The seat capacity for the Eurostar fleet depends on the type of rolling stock used. The older Eurostar rolling stock have 480 seats (the ETR 450, 460 and 480 models) as they only have only 9 carriages while the newer rolling stock (the ETR 500) currently has 12 carriages and 671 seats. The number of seats available has increased in recent years as more of the newer rolling stock is transferred to the flagship Milan to Rome route, furthermore from 2002 Trenitalia undertook a program to add a 12<sup>th</sup> carriage to all the ETR 500 rolling stock fleet, which was completed for the December 2004 timetable change date. Given this change in rolling stock and the upgrading of the existing rolling stock there has been a steady increase in the number of seats available which has only been dampened by the changes in the frequencies, as shown in the figure above.
- 6.13 The figure below shows the historical trend in seat availability for the main airline operators on this route as well as for Trenitalia Eurostar services (it does not include slower trains on the route).

**FIGURE 6.2 MARKET SHARE OF THE RAIL AND AIR AVAILABLE SEATS (TOTAL PER YEAR)**

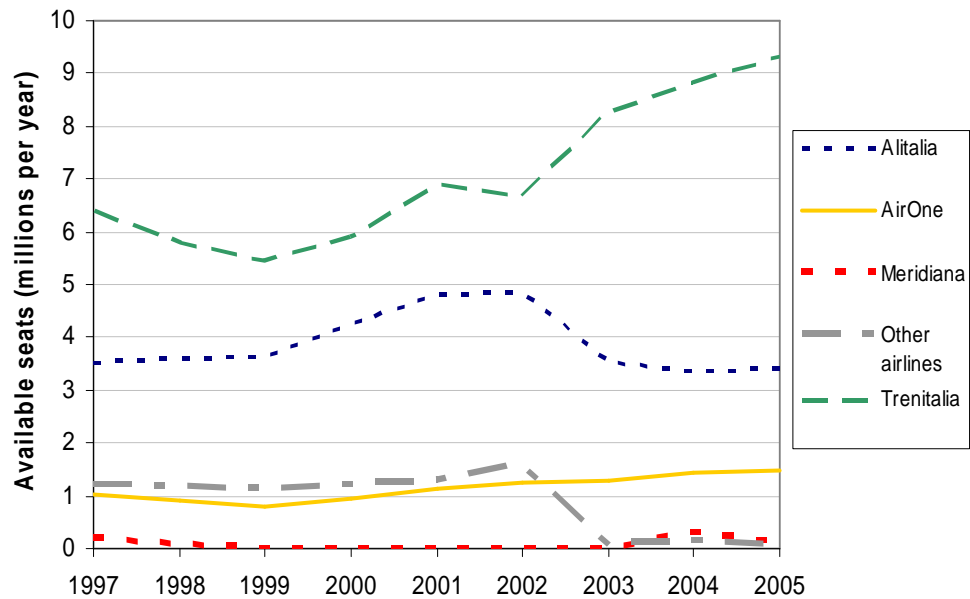

6.14 The figures below shows the market share of the various operators on the Milan to Rome route based on seat capacity. The figure shows that between 1997 and 2005, there was a small increase in the total number of seats available. Furthermore, the share of capacity provided by the airlines has decreased substantially as more Eurostar trains have been put into service on the Milan to Rome route. However, almost all Eurostar trains stop at Bologna and Florence, and so a proportion of seats are used for passengers travelling to these destinations.

**FIGURE 6.3 MARKET SHARE OF THE RAIL AND AIR AVAILABLE SEATS (TOTAL PER YEAR)**

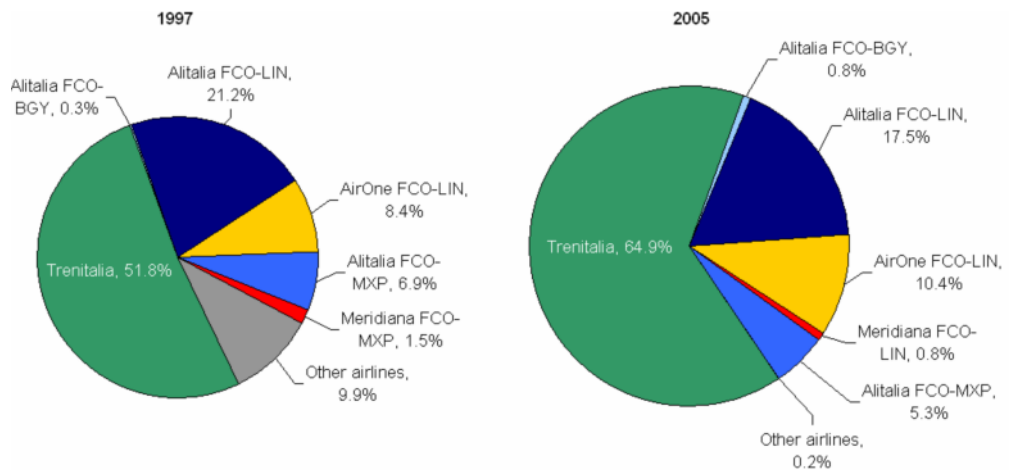

Source: Alitalia, Meridiana, Trenitalia (only Eurostar), SDG analysis

6.15 In 2005, when looking at the total seats available on the Milan to Rome route (both rail and air) the Eurostar services provided about 65% of seats on the route, even

though they only provided about 16% of frequencies. Of the remaining market share for seat availability, Alitalia had the largest share, followed by AirOne and Meridiana.

- 6.16 On the airline route with the most departures, the Linate to Fiumicino route, average cabin occupancy varied from about 53% to about 65%. On the Milan to Rome route the load factor for the Eurostar railway services was 54% in 2005.

**Market size and share**

- 6.17 Figure 6.4 below shows the market share of the operators on the Milan to Rome route based on number of passengers. Data is shown for 2005, prior to the entry of Blue Panorama or Ryanair to the market. Although Trenitalia provides 65% of all seats on the route, it only conveys 38% of passengers. Alitalia carries the largest number of passengers on the route, having a total market share of 42% if its three routes (Linate, Malpensa and Bergamo) are combined. The only other operator with significant market share is Air One. The rail market share is high relative to other European routes with equivalent rail journey times.

**FIGURE 6.4 RAIL AND AIR PASSENGER MARKET SHARE 2005**

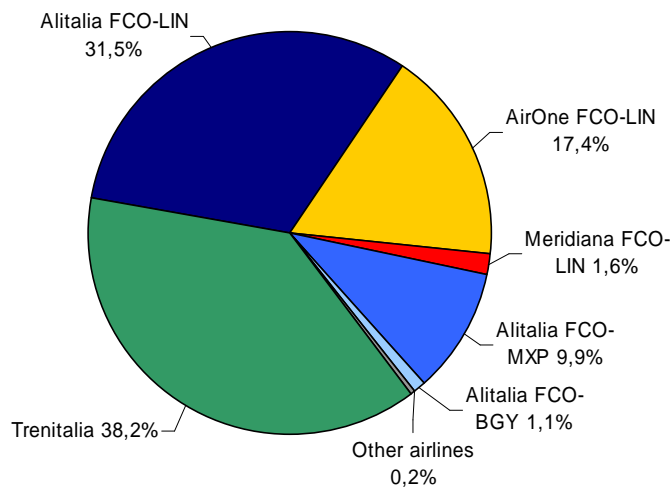

Source: Alitalia, Meridiana, Trenitalia (only Eurostar), Steer Davies Gleave analysis

- 6.18 The figure below shows the change in the total number of passengers for each of the companies on this route since 2003. There has not been a significant change in market share during this period.

**FIGURE 6.5 RAIL AND AIR PASSENGERS**



Sources: ENAC, Alitalia, Trenitalia (only Eurostar), Steer Davies Gleave analysis

Note: figures in thousands passengers.

6.19 As shown in Figure 6.6 below, a proportion of Alitalia passengers using the route do so in order to connect with other air services at either Milan or Rome ('hub' passengers). Rail is not an alternative for these passengers, as the long distance trains do not serve the airports. Taking this into account, we estimate that rail has a 42% share of the point-to-point market and is likely to carry marginally more passengers than Alitalia.

**FIGURE 6.6 HUB AND LOCAL ALITALIA PASSENGERS (2005)**

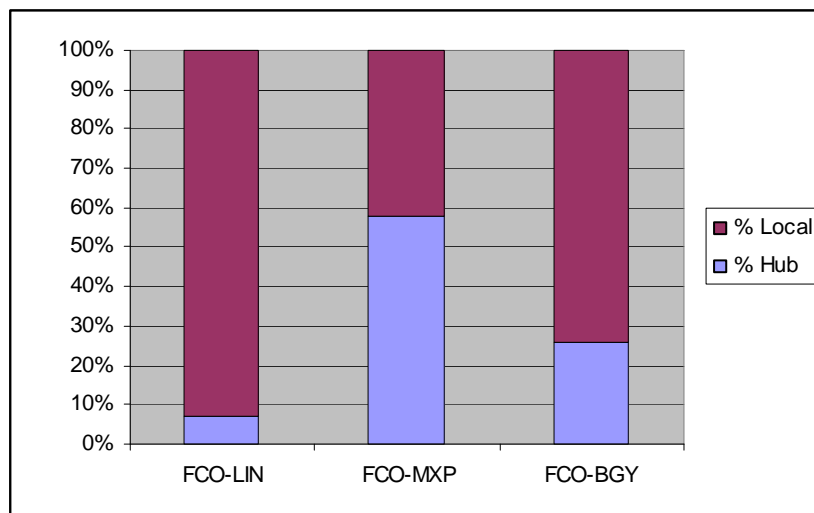

Source: Alitalia

**Other modes of transport**

- 6.20 In addition to rail and air travel, car travel is possible on the route. The average journey time taken to drive from Rome to Milan is about 6 hours, and motorway tolls are €29.50.
- 6.21 There are no direct scheduled bus services currently licensed to operate on this route. A number of bus services operate from south of Rome to Milan and they stop off in Rome: however, due to regulatory restrictions imposed by the Italian government, it is not possible to buy a ticket between Rome and Milan. There is a bus company that offers a Rome to Milan service but it is necessary to buy two separate tickets and change buses in Siena.

**Access to the services**

- 6.22 Although the rail stations are more conveniently located for the city centres than the airports, a significant proportion of passengers travelling by air from the Milan and Rome airports are actually travelling from the areas around the cities. For these passengers, air travel may be more convenient. Most trains do not stop at any stations in the Milan and Rome regions other than Milan Centrale and Rome Termini.

**Milan**

- 6.23 Given the population density around Milan, the catchment area for the three airports near Milan is very large and includes the provincial areas around the province of Milan. This is also due to the fact that Malpensa and Orio al Serio are respectively 50kms and 40kms from the centre of Milan and that there are large population areas closer to these airports than the centre of Milan. The table/figure below sets out the populations of the various council areas around the three airports.

**FIGURE 6.7 POPULATION OF THE MILAN CATCHMENT AREA (2003)**

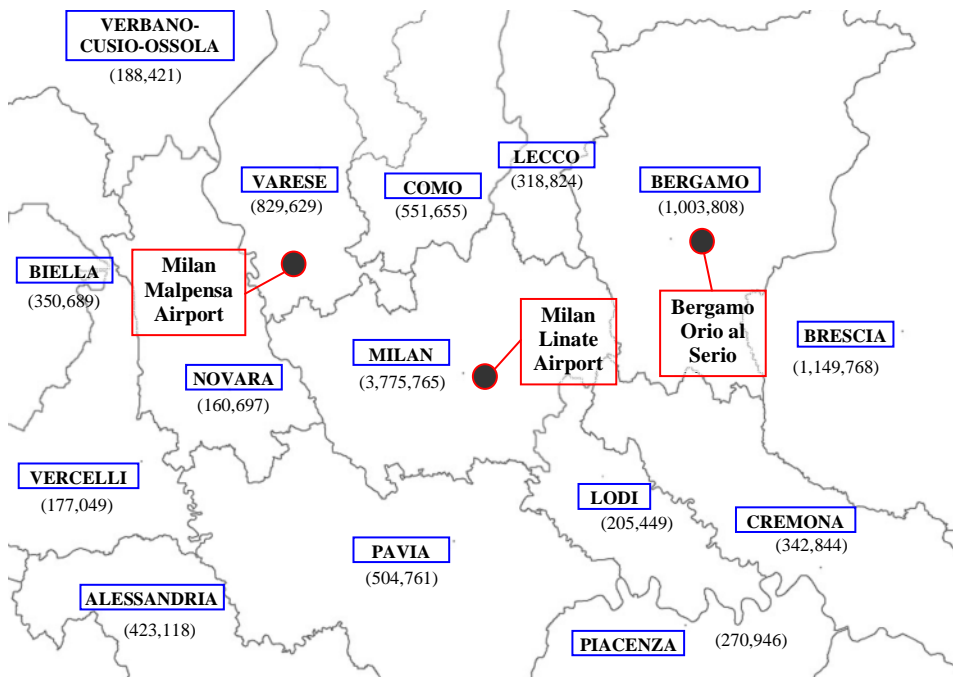



Source: ISTAT

6.24 A survey undertaken by DOXA on behalf of SEA, the Milan airports authority, also established the origin of the passengers using the Milan airports. Only 37% of passengers using the airports actually travel to/from central Milan. Therefore, the availability of three alternative airports located around the city represents an advantage for the airlines relative to the rail operator.

**FIGURE 6.8 MALPENSA AND LINATE PASSENGER ORIGIN (2005)**

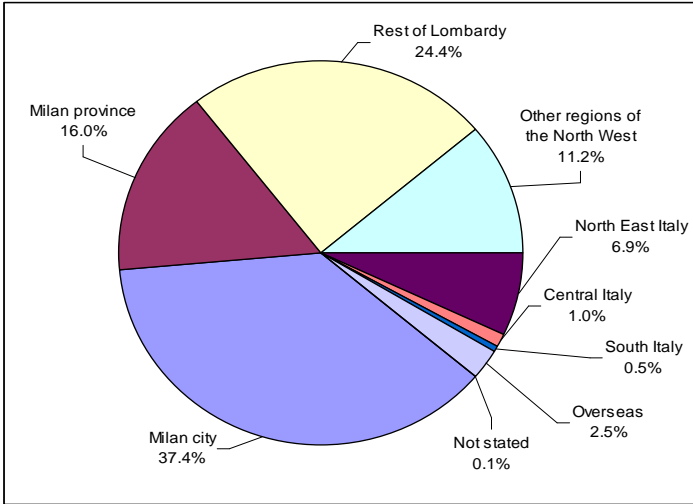

Rome

6.25 There is currently no information available for the surface origins and destinations of passengers using the Rome airports. However, the population of the area is more concentrated within Rome itself.

FIGURE 6.9 POPULATION OF ROME CATCHMENT AREA (2003)

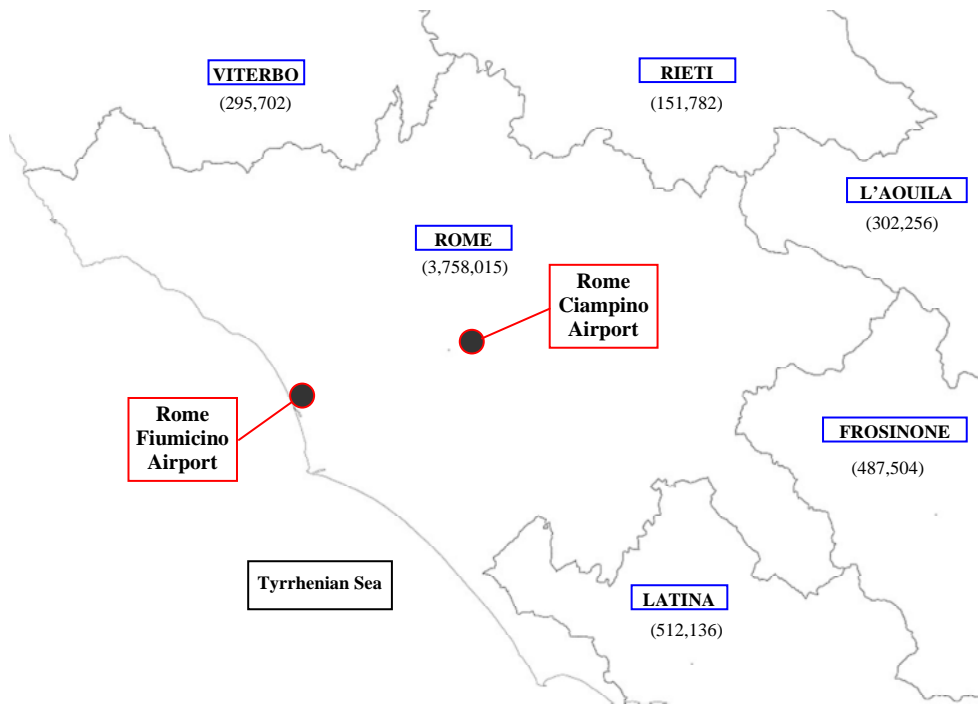

Source: ISTAT

#### Airport connections

- 6.26 The train stations in Milan and Rome are both significant distances from the main airports and there is no commercial agreement between Trenitalia and the airlines to facilitate connecting travel. In principle, it would be possible to run a Eurostar service between Rome and Malpensa or between Milan and Fiumicino. However, the stations would require substantial upgrades to accommodate Eurostar trains and there are currently no plans to run such a service.

#### Milan

- 6.27 In Milan, the connection between Milano Centrale train station and the three airports in question is not straightforward. For Malpensa, passengers arriving at the train station must either board a direct bus to the airport at a cost of €5 which takes 50 minutes, or must take the metro to another train station, from which they then take the Malpensa Express train, at a cost of €11, which takes 40 minutes. Alternatively, they can take a taxi at a cost of €70. For Milano Linate, passengers can catch an urban bus from the station at a cost of €1 or a taxi for €15. For Bergamo Orio al Serio there is a connecting bus at a cost of €6 that takes 1 hour.

#### Rome

- 6.28 There are better connections between Rome Termini (the main station) and Rome Fiumicino airport. There is a direct, non-stop train service at a cost of €9.50 which connecting Eurostar passengers can take to the airport. The journey time is 31 minutes. Alternatively there is a bus that takes 70 minutes at a cost of €15 return, or a taxi at a cost €40.

## Fares

### Level of fares

- 6.29 We have compared fares on the Milan to Rome route for over 30 potential journey combinations, in order to estimate average fares in the air sector. The main airlines, Alitalia and Air One, levy fares that are much higher than those levied by the rail operator – even for the premium ‘TBiz’ service. In general, rail fares in Italy are low compared to fares in many other European states. Our fare data collection was started before the lower cost operators entered the market and therefore we do not have comparable data for these operators. Our estimates of average fares are shown in Figure 6.10 below.

**FIGURE 6.10 MILAN-ROME AVERAGE SAMPLED FARES**

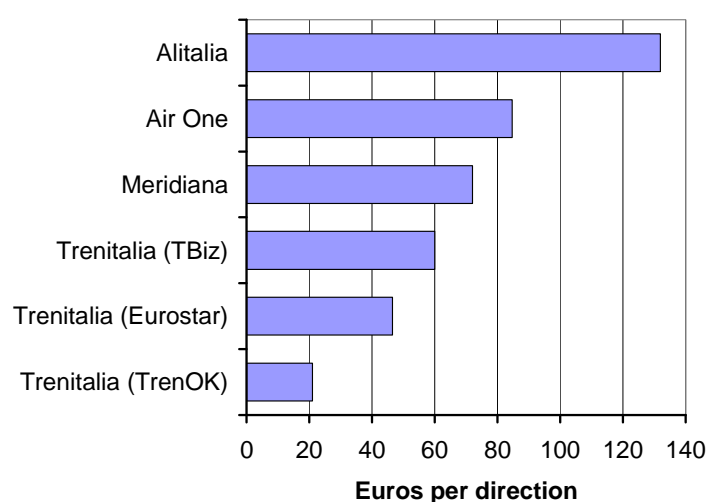

Source: Operator websites

- 6.30 The standard price for a second class return Eurostar ticket on Trenitalia between Roma Termini e Milano Centrale is €92.96. For the TBiz service the cost increases to €120.00 while for the TrenOK service the cost varies from 18 € booked well in advance to €50 if booked 1 day before. The low-cost airlines Ryanair and Blue Panorama are the only airlines that offer any advanced booking fares below the standard Eurostar fare.
- 6.31 There is some variation in fares between different journey times and travel options (for example, single and return tickets). Figure 3.9 compares fares for two specific journey types – a return journey over a weekend booked 2 months in advance (typical for a leisure passenger), and an overnight journey booked 1 day in advance (more typical for a business passenger). In both cases, the classic airline’s price remained the same for 2 of the 3 airports, but the low and lower cost carriers had substantial differences in their prices. Except for TrenOK which charges according to the number of advanced bookings it receives, the other rail services maintain the same prices and level of flexibility. We found that the Ryanair flights, which were introduced during the course of our study, were often booked up at short notice and if these were available, prices were very high.

FIGURE 6.11 ROME - MILAN RETURN FARES

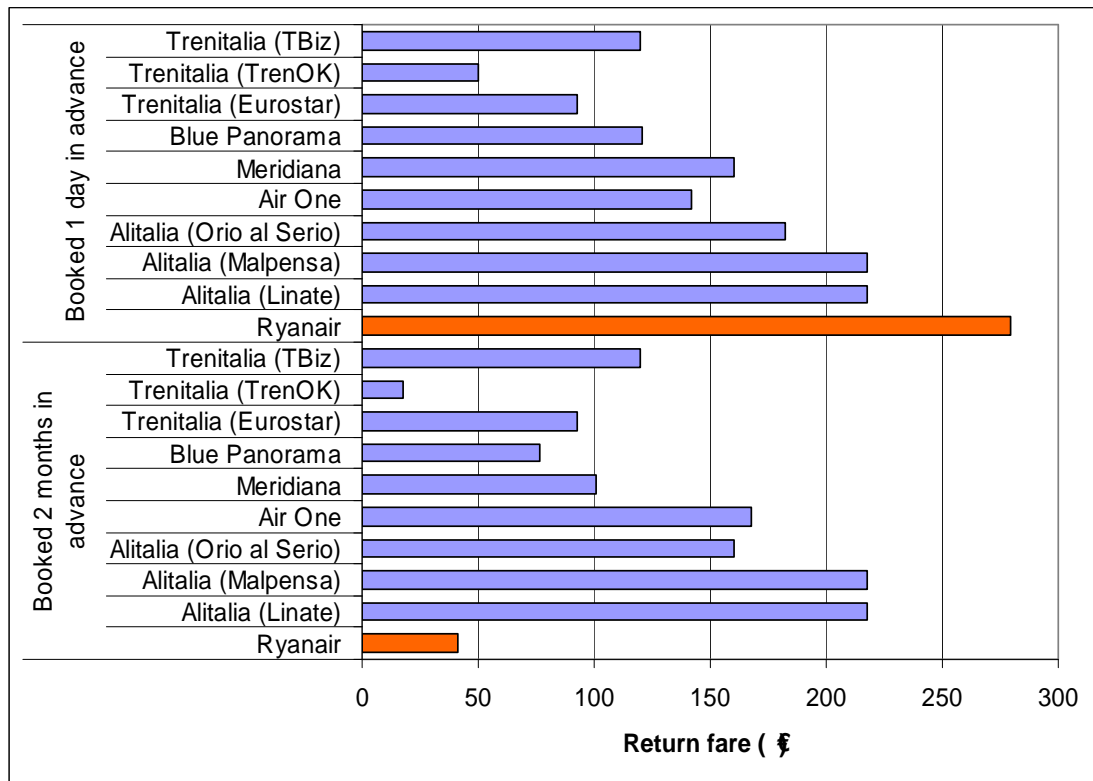

Source: Company websites

- 6.32 In the case of Alitalia, not only are the tickets generally more expensive than the other operators, they are also less flexible. To obtain a cheap fare with Alitalia, it is necessary to stay over a Saturday night and buy a return ticket, restrictions that do not apply for the other airlines or for Trenitalia. Furthermore, discounted tickets for Alitalia and Air One are non-changeable/refundable, whilst Meridiana, Blue Panorama and Ryanair offer the ability to change the booking and the name of the traveller but with the payment of an administrative charge. Fully flexible fares were only available from Alitalia, AirOne, and Meridiana with AirOne requiring the payment of an administrative fee for all changes, Meridiana requiring payment for only some changes and Alitalia not requiring the payment of any fees.
- 6.33 On the railways, Trenitalia allows changes to reservations for all Eurostar and TBiz passengers (before departure) without any charge to the traveller, however the only way to change TrenOK tickets is to pre-purchase a right to change the tickets for €5.

Evolution of fares

- 6.34 The only airline that has been operating continuously on the Milan-Rome route is Alitalia. Originally, Alitalia fares were calculated based on a charge per km travelled. Subsequently, a number of new fare types were introduced accompanied by different flight restrictions. Since 1997, the full fares (known as Y-fares) have been steadily increasing as shown in the figure below. However, this does not necessarily imply that average fares have increased, as a range of discounted fares is now available. We do not have information on the trend in average fares.

FIGURE 6.12 CHANGE IN ALITALIA FARES 1997-2006

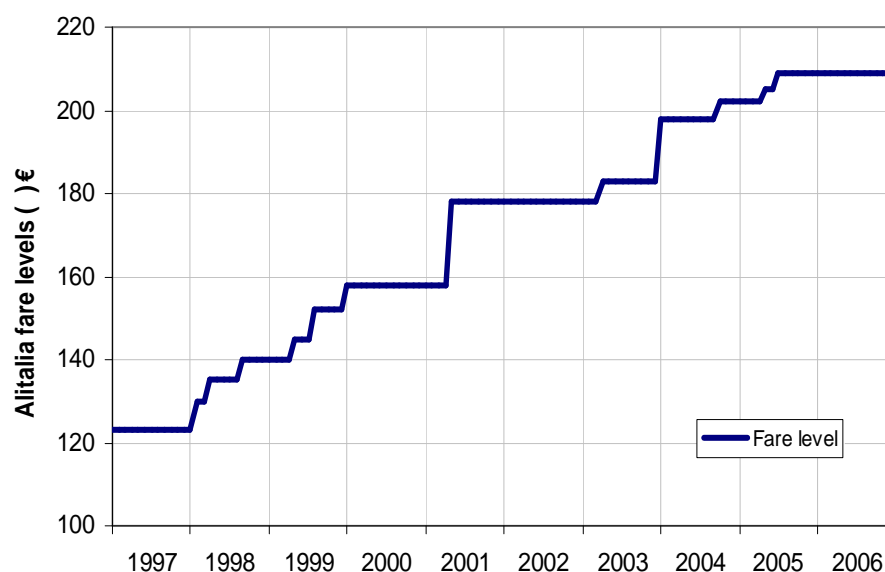

Source: Alitalia, relating to Y-fares (maximum fares)

- 6.35 The standard fares for all train services, including Eurostar services, have not changed since 2000 and therefore have seen a real fall in prices of about 15%. Trenitalia have tried to reduce the impact of this fall by introducing new tariffs to encourage people to use Eurostar services as well as offer higher value services such as the TBiz Eurostar service.

#### Purchasing tickets

- 6.36 All airlines on the route allow tickets to be purchased on their website. All of the operators charge higher fees for booking by telephone and all operators charge a credit card booking fee. Trenitalia allows tickets to be booked on its website and can provide the passenger with an e-ticket as do the airlines.

#### Service quality and on board services

- 6.37 The table below compares various service quality characteristics for Eurostar and the airlines, and the terminals/stations that these serve. The level of on-board service on this route is very minimal with none of the airlines providing business class, and the level of catering is reduced to the bare minimum on Alitalia and AirOne. On Blue Panorama, food can be bought on board the aircraft, but it is not available at all on Meridiana flights. On Eurostar, there is a small catering service provided in first class, but nothing in second class: travellers can use the on-board restaurant and snack bar.

TABLE 6.2 PASSENGER SERVICES ON BOARD AND AT AIRPORT/STATIONS

	Eurostar	Alitalia	AirOne	Meridiana	Blue Panorama
<b>On board service quality</b>					
Seat pitch (2nd class)	Not known	Approx 80cm	77-78cm	77-78cm	72-73cm
Catering included	✗	Snack/drinks	Snack/drinks	✗	✗
Check in baggage limit	No limit	20kg	20kg	20kg	15kg
Pre-assigned seating	✓	✓	✓	✓	✗
Magazine available	✓	✓	✓	✓	✓
1st class available	✓	✗	✗	✗	✗
Key differences in 1st class	Larger seat and snacks/drinks	N/A	N/A	N/A	N/A
<b>Airport / terminal facilities</b>					
Catering facilities	✓	✓	✓	✓	✓
Retail outlets	✓	✓	✓	✓	✓
Heated/secure waiting lounge	✓	✓	✓	✓	✓
Toilets	✓ (but charge)	✓ (free)	✓ (free)	✓ (free)	✓ (free)
Business lounge available	✓ (restricted to Club Eurostar)	✓ (restricted to Club Ulisse)	✓ (Only with frequent flyer card)	✗	✗
Business lounge open to all 1st class passengers	✗	N/A	N/A	N/A	N/A

6.38 The Eurostar stations are normal railway stations and as such do not have security checks. They do provide a lounge that is accessible to all travellers with a certain loyalty card.

### Reliability

6.39 The data for Alitalia for the year 2005 on the route between Milan Linate and Rome Fiumicino are shown in the table below which sets out the total delays and their principle causes, when this is within the control of Alitalia. 30% of flights operate more than 5 minutes late.

**TABLE 6.3 RELIABILITY DATA: ALITALIA 2005**

	Delays within the control of Alitalia		Other causes of delay
	Technical	Strikes	
Departures > 5 mins delay	0.7%	0.3%	
Departures > 60 mins delay	0.05%	0.08%	28.2%
Cancellations	0.02%	0.002%	

- 6.40 Data provided to us by Trenitalia shows that the 90% of Eurostar trains arrive within 10 minutes of their allotted arrival time on this route.

### Taxes and subsidies

#### Railways

- 6.41 Each year there is a line item in the national budget that allocates funds to the railways. This public contribution is paid directly to the companies within the industry in the form of payments for the provision of a public service, under a service contract. These payments are currently paid nationally to the infrastructure manager for operating, maintaining and renewing the rail network as well as to Trenitalia both for the operation of certain socially necessary freight services and for some national passenger services. Regional governments have similar contracts with Trenitalia for regional services. The national passenger service subsidies are as yet not distinguished between Eurostar and non-Eurostar services. However, it is generally believed that Eurostar services do not absorb any of the subsidies.
- 6.42 The funding of the high speed line investments has been arranged through loans taken out by TAV, the company in charge of the construction of the high speed lines.
- 6.43 The tables below show the payments that have been made to the Italian railways in recent years.

**TABLE 6.4 NATIONAL GOVERNMENT FUNDS ALLOCATED TO FERROVIE DELLO STATO**

Year	Amount allocated (€ billions)
2001	3.7
2002	4.3
2003	3.8
2004	2.8
2005	3.0

*Source: Finanziaria 2001-2005*

- 6.44 The breakdown in relation to the State contributions paid to the various business units of FS Holding was only undertaken from 2002. The table below sets out the amount of State contribution paid out to those business units for the years 2002 and 2003.

TABLE 6.5 STATE CONTRIBUTIONS TO OPERATIONS

State contribution to	Annual amount provided (€ bil.)	
	2003	2002
Trenitalia (passengers)	1.23	1.22
Trenitalia (freight)	0.48	0.48
Trenitalia (others)	0.04	0.04
RFI	2.05	2.56

*Source: Trenitalia Accounts 2003, SDG calculations*

#### Airlines

- 6.45 None of the airlines on this route receive any form of state subsidy for services on this route. However, Alitalia has in the past had State contributions to avoid bankruptcy and is currently benefiting from a €400 million state bridging loan to finance its activities.
- 6.46 The airlines pay fuel and corporate taxes to the Government, as well as (until January 2006) royalties on fuel replenishments to the airport operators.
- 6.47 While there is potential for growth both at the Milan and the Rome airports because of slot availability, the specific case of Milan Linate airport is unique. This airport, although it has spare capacity, has no further slots available and will not accept any new operators, as a result of the airport operating company's decision to focus all growth on Malpensa airport when the improvements to Malpensa were completed in 2000.

#### Future developments

- 6.48 As has been shown above there will be a substantial reduction in journey times for the Eurostar services when the high speed line between Rome and Milan has been completed. This change is likely to have a substantial affect on the number of a passengers choosing the train over the airlines. Figure 6.13 shows the projected Milan-Rome journey time: this should fall to around 3 hours by 2012.



FIGURE 6.13 CHANGES IN JOURNEY TIMES 2006-2012

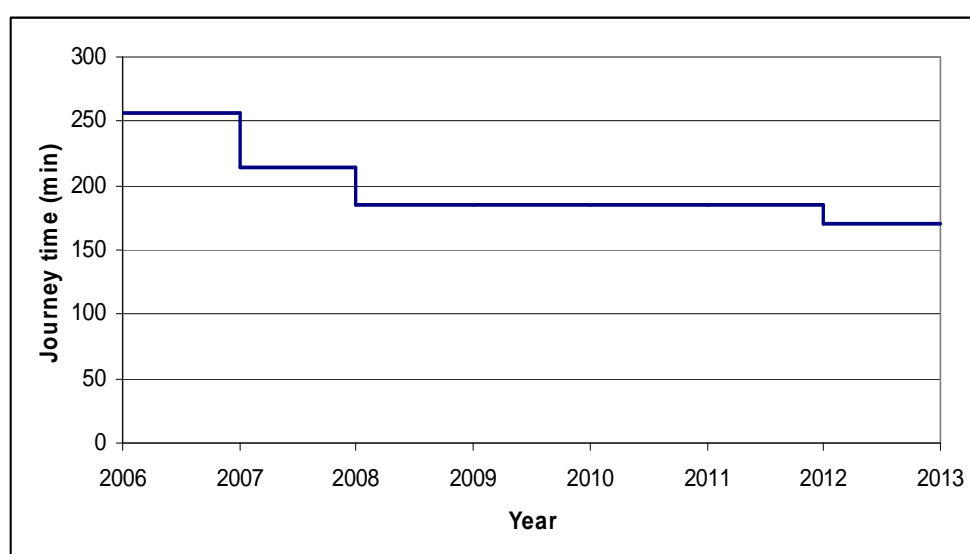

Source: Trenitalia

- 6.49 Ryanair has recently entered the route, with a twice-daily service between Bergamo Orio al Serio and Rome Ciampino. Based on evidence from the booking system, this appears to have been quite successful: flights often seem to be fully booked and, probably as a result of this strong demand, fares seem high compared to other Ryanair routes. At present, with only two flights per direction per day, the Ryanair service is unlikely to have had a significant impact on the other operators, but this will change if Ryanair increases the number of flights that it provides in the future. However, the low fares currently offered by Trenitalia are likely to limit the share that can be obtained by low cost airlines. If Trenitalia continues to offer equivalently low fares when the high speed line is complete and therefore the journey time advantage of air transport is eroded, the potential for low cost air services will be reduced.
- 6.50 There are currently no plans to provide connecting services between the Eurostar trains and the airports, nor are there plans to build any high-speed stations at the major airports analysed, so interchange between the two modes will remain through either the rail or bus shuttle services connecting the airports to the main stations of Rome and Milan.

### Conclusions

- 6.51 Taking into account the relatively long journey time, rail achieves a high market share on the Milan-Rome route (38%, and 42% of point-to-point passengers). This high share reflects the low fares offered by Trenitalia and the lack of competition from low cost airlines to date. Travel by rail is almost always cheaper than travel by air on this route. In addition, the regulatory restrictions on bus competition mean that price-sensitive passengers have to travel by rail, rather than by bus as they might in (for example) Spain or the UK. The availability of lower-priced rail options, including the TrenOK service and the slower InterCity and night services, provide an alternative option for very price-sensitive passengers.

- 6.52 At present, however, time-sensitive business passengers are likely to travel by air. The opening of the new sections of high speed line on the route between Milan, Bologna and Florence, and the upgrading of the Florence-Rome section to 300km/h operation, should result in the journey time being reduced towards 3 hours. This is likely to improve rail market share significantly, as some time-sensitive passengers will transfer from air transport. It is estimated by the stakeholders that the improvements in journey times mentioned above are likely to lead to about 15%-20% increase in the market share of rail in terms of passenger numbers. However, the relatively dispersed origins/destinations of passengers, particularly in the Milan region, will help protect air market share. In addition, if rail fares increase in the future, there will be more opportunities for low cost airlines to enter the market.

---

## 7. PARIS - MARSEILLE

### Introduction

- 7.1 Marseille has been served by the TGV from Paris since the opening of the first high-speed line between Paris and Lyon in 1981. Initially, however, services could only operate at high speeds between Paris and Lyon, and then continued via the conventional network. The high speed line was extended to Valence in 1994 and then to Marseille with the opening of the TGV Méditerranée (TGV Med) in 2001.
- 7.2 The main service operates from Paris Gare de Lyon station in central Paris, but there is also now a service from CDG airport. As well as the regular TGV service, in December 2004 SNCF launched a 'iDTGV' ("interactive-Relaxation High Speed Train"), targeted at the low-cost leisure market. Bookings can only be made online and it is promoted on the basis of its cheap fares and range of on-board services and entertainment.
- 7.3 The only airline currently operating on the route is the French national network carrier, Air France, which operates flights from both CDG and Orly airports; no low cost carriers currently serve the route. easyJet experimented with a service from Paris Orly, but ceased to operate this from March 2005.
- 7.4 Unfortunately, SNCF did not provide information or assistance for this case study and, compared to other European rail operators, it generally releases little data into the public domain. As a result of this, there are some aspects where the analysis we have been able to carry out has been limited.

### Service provision

#### Journey times

- 7.5 Average journey time by TGV between Paris Gare de Lyon and Marseille St Charles is about 3 hours 10 minutes; the fastest journey time, 3 hours, is achieved by three trains per day (in one direction only) which run non-stop. Although in principle the journey time from CDG airport need not be any longer than the journey time from central Paris, in practice trains travelling to/from CDG take about 30 minutes longer, as most make more intermediate stops.
- 7.6 The journey time was reduced by approximately 75 minutes in June 2001 when TGV Med, the extension of the high speed line from Valence to Marseille, was opened. Journey times through the past decade are summarised in Figure 7.1.

FIGURE 7.1 TGV JOURNEY TIMES

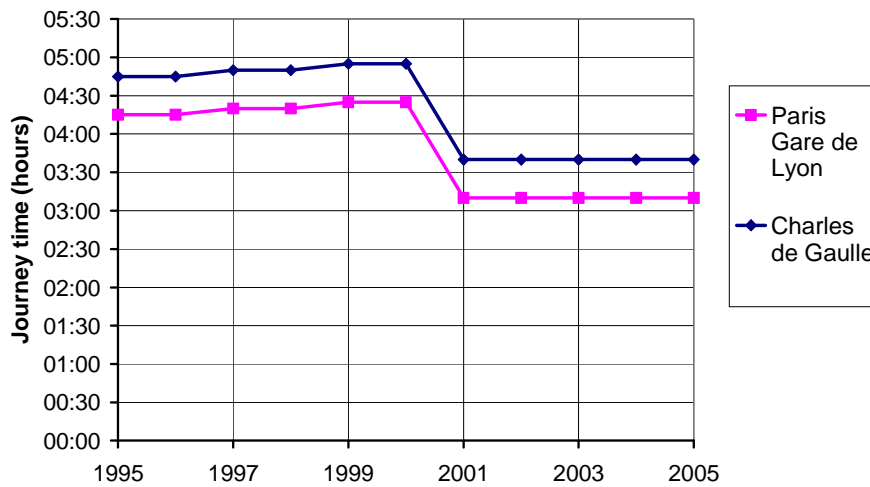

Source: Thomas Cook European Rail Timetable

7.7 Scheduled air journey time is approximately 1 hour 15 minutes from Paris Orly airport and 1 hour 25 minutes from CDG. The additional journey time allowed by Air France from CDG is due to greater congestion and taxiing times, rather than significant differences in flight time.

#### Frequency and available seats

7.8 On weekdays there are currently 17 trains per day to and from Paris Gare de Lyon (one of which is an 'iDTGV', SNCF's low-fare service launched in December 2004), and 7 trains per day to and from CDG airport. Services were stepped up significantly in 2001 with the opening of the TGV Méditerranée extension, when a total of 7 new trains per day were added between Marseille and Paris.

7.9 Air France offers 20 flights per day on weekdays from Orly and a further 6 from CDG. Air competition on this route has reduced steadily during the past decade: previously, AOM French Airlines still operated, and Air Inter still flew their own schedule prior to their merger with Air France in 2001. Air frequency reached its peak in 1999 when 45 flights were operated per day.

7.10 easyJet also experimented with offering a service between Paris Orly and Marseille in 2004, operating 2 flights per day. However, it ceased to provide this service in March 2005 and no other low cost airline has attempted to provide services on this route. Trends in frequency are summarised in Figure 7.2.

FIGURE 7.2 RAIL AND AIR FREQUENCY (EACH WAY)

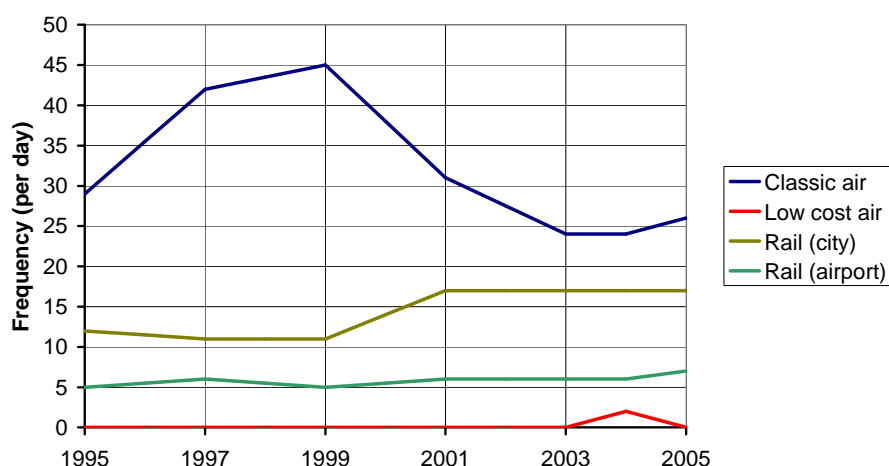

Source: Thomas Cook European Rail Timetable, OAG airline guide

- 7.11 For our other case studies we have sought to carry out an analysis of seat capacity offered by each mode. Such an analysis is not possible on this route, because the capacity of the trains operated varies significantly. A standard TGV has approximately 370 seats, but SNCF also uses TGV Duplex on this route, with a capacity of 512 seats. At busy times, SNCF also runs two units coupled together, so a train can have up to 1,024 seats. It is therefore not possible to evaluate levels of rail capacity provision from historical timetable information.
- 7.12 Air France have consistently flown Airbus A319, 320 and 321s on the route in recent times. These have an average capacity of about 150 passengers per flight, much lower than the capacity of even single-decker unlinked TGV. It is therefore possible to conclude that TGV capacity is greater than air capacity. The TGV does, however, make some intermediate stops and some of its capacity will be accounted for by passengers embarking and disembarking at these stops.

#### Market size and share

- 7.13 As explained above, SNCF did not provide information or assistance for this case study. This has limited the analysis that we have been able to do of market size and share. However, air passenger data is available, and some limited rail data was released as part of analysis of the impact of TGV Med.
- 7.14 Figure 7.3 shows the trend in air passenger numbers between Paris and Marseille since 1995. These reached a peak in 2000 when nearly three million passengers travelled by air. Numbers dropped sharply in 2001 and 2002, reaching a steady level of just over two million in 2003 and 2004; data is not yet available for 2005. The general effect which the terrorist attacks of September 11<sup>th</sup> 2001 had on air passenger travel worldwide will account for some of this decline. However, this will only have exaggerated the effect of the primary cause: the opening of the TGV Med in 2001. Rail journey times were cut and service frequency was increased, significantly improving the competitiveness of rail travel on the route relative to air. Indeed, whereas Air France's

overall domestic passenger numbers have shown some recovery since 2001<sup>2</sup>, this has not been the case on the Paris-Marseille route.

**FIGURE 7.3 PARIS-MARSEILLE AIR PASSENGERS**

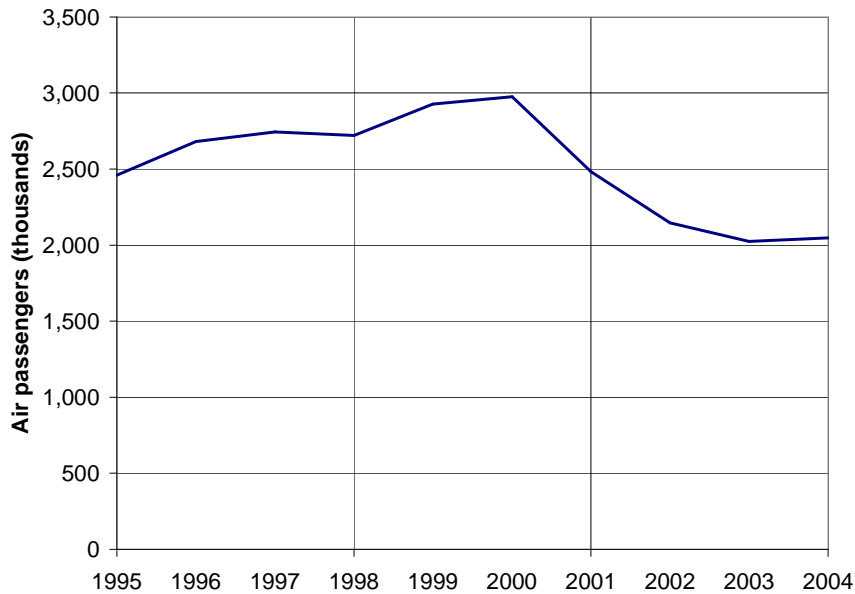

Source: DGAC

7.15 Data is not available for TGV passenger numbers, however according to the French civil aviation authority (DGAC), rail currently accounts for approximately 67% of the total air and rail passengers travelling between Paris and Marseille. This is consistent with information from Air France, which, in a 2004 press release, described their market share as being less than 35%. DGAC have also published data for travel between the Ile-de-France and Provence-Alpes-Côte d’Azur (PACA) regions for 1996 (pre-TGV Med) and 2003 (post-TGV Med). This is shown in Figure 7.4. Despite the total market for travel between Ile-de-France and PACA growing by 25% over the period illustrated, air passenger numbers declined. All of the growth for travel between the two regions was seen in rail, as a result of which the rail market share rose from 39% to 58%.

<sup>2</sup> Bulletin statistique, ministère des Transports de l’Équipement du Tourisme et de la mer, March 2006

FIGURE 7.4 ILE-DE-FRANCE – PROVENCE-ALPES- CÔTE D’AZUR PASSENGERS

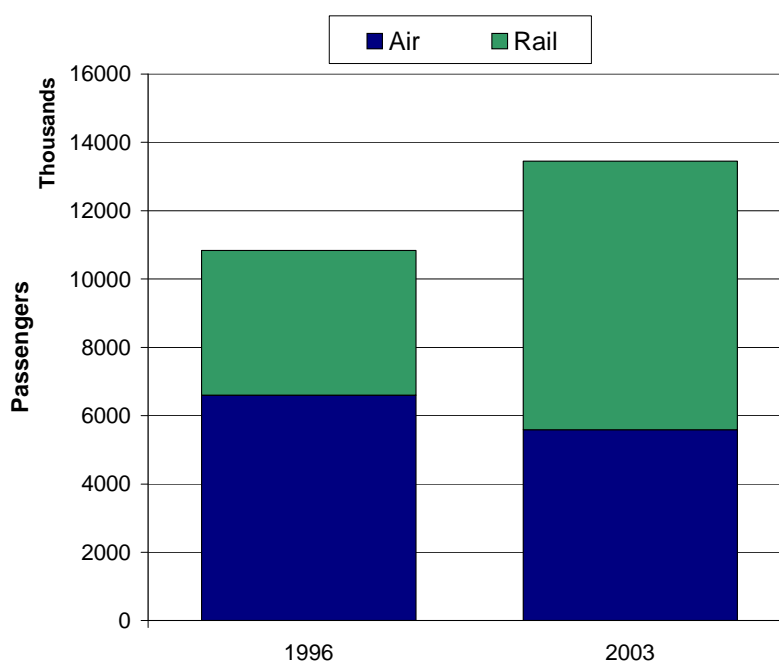

Source: DGAC

- 7.16 The change in mode share is particularly pronounced considering the fact that the PACA region includes Nice, which is served directly by a large number of air services from Paris (including frequent low cost services operated by easyJet), but for which rail journey times are much longer, as it is not on the high speed network. Without co-operation from SNCF we were unable to carry out any further market share analysis.
- 7.17 Rail's share of the Paris-Marseille market is likely to be even higher if we take into account the fact that a proportion of air passengers will be connecting to onward services. In 2004/05, of Air France's passengers on all routes at Paris CDG, 53% were making connections to onward flights<sup>3</sup>. The figures shown will therefore underestimate rail's share of the point-to-point market, which we estimate to be 80-85%.

#### Access to the services

- 7.18 The ultimate origin and destination of passengers is significant in determining market share, to the extent that it will determine the relative accessibility of the air and rail terminals. Marseille Saint Charles and Paris Gare de Lyon stations are both located centrally, whereas the airports serving the respective cities are outside the city centres. To be representative of convenience for passengers, check-in times should be added to the access times given below. These are a minimum of 5 minutes for the TGV, 20 minutes for Air France Orly flights, and 30 minutes for CDG flights.

<sup>3</sup> Aviation Strategy Issue No 101, March 2006

## Paris

- 7.19 Table 7.1 contrasts the population distribution in Paris with air passengers' origins and destinations. Note that this data is for all direct air passengers using the airports, not just for passengers on the Paris–Marseille route. Whereas the central area accounts for only 19% of Paris' population, it accounts for over half of origins and destinations for passengers of the Paris airports. This reflects the concentration of tourist and business locations in the city centre. The table excludes air passengers originating in areas outside of Paris (10.4%) and outside of France (0.2%).

**TABLE 7.1 DISTRIBUTION OF POPULATION AND PASSENGERS - PARIS**

Area of Paris	Population (000s)	Share of population	Share of origin/destination air passengers
Central	2125	19%	52%
Inner suburbs	4039	37%	38%
Outer suburbs	4788	44%	

- 7.20 It is possible to access CDG and Orly airports from Paris city centre by train, bus, car or taxi. The travel times and associated costs for each mode are presented in Table 7.2. For CDG, rail is both the cheapest and the quickest mode, whereas for Orly bus and rail are similarly priced and bus is the quickest.

- 7.21 The equivalent information for Gare de Lyon is not available, since the terminal is located in the city centre. This location makes it significantly more accessible for travellers to the central area, but less so for passengers from outside of central Paris.

**TABLE 7.2 ACCESS TIMES AND COST FROM CITY CENTRE FOR THE PARIS AIRPORTS**

	Rail		Bus		Car/taxi		
	Time (mins)	Cost (€)	Time (mins)	Cost (€)	Time (mins)	Cost of 24hrs parking (€)	Cost of taxi (€)
CDG	35	8	60	8.4	45	15-23.5	50
Orly	45	5.65-9.05	30	5.80	35	11.7-21.20	35

## Marseille

- 7.22 The population of Marseille is more centrally concentrated than that of Paris, albeit smaller overall. The total population is 1.35 million, of which 60% live in the central area and the remainder live in the suburbs. The rail terminal is therefore conveniently located for a high proportion of potential customers in the Paris-Marseille market.
- 7.23 The airport is located outside of the city centre and can be accessed by bus, car or taxi. Access times and costs are given in Table 7.3



**TABLE 7.3 ACCESS TIMES AND COSTS FROM CITY CENTRE FOR MARSEILLE AIRPORT**

	Bus		Car/taxi	
	Time (mins)	Cost (€)	Time (mins)	Cost of 24hrs parking / taxi (€)
Marseille Marignanne	25	8.5	25	10.5-13.5 / 40

### Fares

#### Level of fares

7.24 Overall, we found that the fares offered for travel on the TGV were generally cheaper than those offered by Air France. We collected a large sample of fares in order to try to estimate average fares for the operators: we found that the average fare levied by Air France (€135 per direction) was more than twice that levied for the TGV ( €60). This difference is contributed to significantly by the very high prices found for Air France single tickets (€300), and for flexible tickets (€440 return).

7.25 Figure 7.5 compares return fares on the Paris to Marseille route for a weekend return ticket booked in 2 months in advance and a midweek day trip booked 24 hours prior to travel, to represent typical 'leisure' and 'business' trips. For the leisure trip we found that Air France is marginally cheaper than the TGV. However, this only applies to travel at certain times (our research focussed on services departing as close to midday as possible) – passengers willing to be flexible and travel on the one iDTGV per day are able to purchase cheaper tickets. 24 hours prior to travel iDTGV is unavailable and it is only possible to buy TGV 'normal' (flexible) fares. Nevertheless, these are significantly less expensive than the equivalent Air France fares.

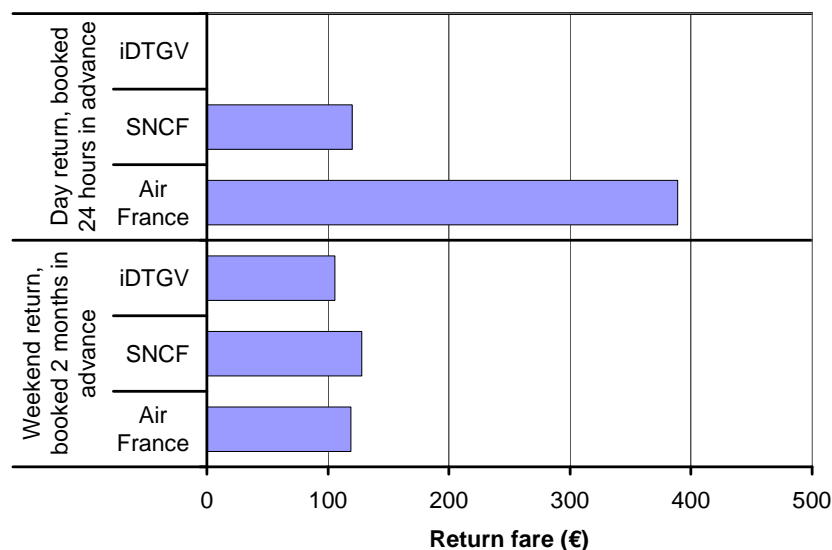
**FIGURE 7.5 FARES COMPARISON FOR PARIS-MARSEILLE**

7.26 These tickets have various conditions attached to them relating to how flexible they are and whether it is possible to obtain a refund on cancellation of travel. These are

summarised in Table 7.4. Generally, low priced air and rail tickets are inflexible on this route.

**TABLE 7.4      TICKET CONDITIONS**

<b>Ticket type</b>	<b>Flexible?</b>	<b>Refundable?</b>
Air France non-flexible economy	No	No
Air France flexible economy	Yes	Yes
iDTGV	Yes, a €10 fee is added if the ticket has already been printed	No
TGV Prem (discounted)	No	No
TGV normal	Yes	Yes, with a fee of 50% of the fare

- 7.27 We also compared the yield management rules used by the operators, as these can result in substantially higher fares for some passengers, especially those not making return trips or those not staying over a Saturday night. We found that Air France charged much more for single tickets and often also charged more for tickets not involving a Saturday night stay; in contrast, the main discounted fare available for the TGV (the ‘Prem’ ticket) was a simple one-way fare with no restrictions. However, these are available in limited numbers and certain other TGV tickets do require a Saturday night stay and purchase of a return ticket.

#### Purchasing tickets

- 7.28 Tickets for both Air France and the TGV can be purchased online with no restrictions on country of residence. iDTGV and TGV Prem tickets are only available online. Both Air France and SNCF also issue e-tickets: in the case of the TGV these can be printed by the passenger in advance and are scanned by ticket staff on the train, thus removing the need to check-in.

#### Price trends

- 7.29 Since 2000 the price of the lowest available air fares between Paris and Marseille have dropped. This reflects Air France’s response to the opening of TGV Med in 2001, and the threat of competition from low-cost carriers. Although these fares have been falling, the price of unrestricted tickets has continued to rise. Air France appear to have followed a strategy of maintaining high yields in specific segments of the market, whilst cutting fares in order to compete for the price-sensitive leisure market. This is illustrated in Figure 7.6. No data on historic rail prices was available.

FIGURE 7.6 TRENDS IN AIR FARES

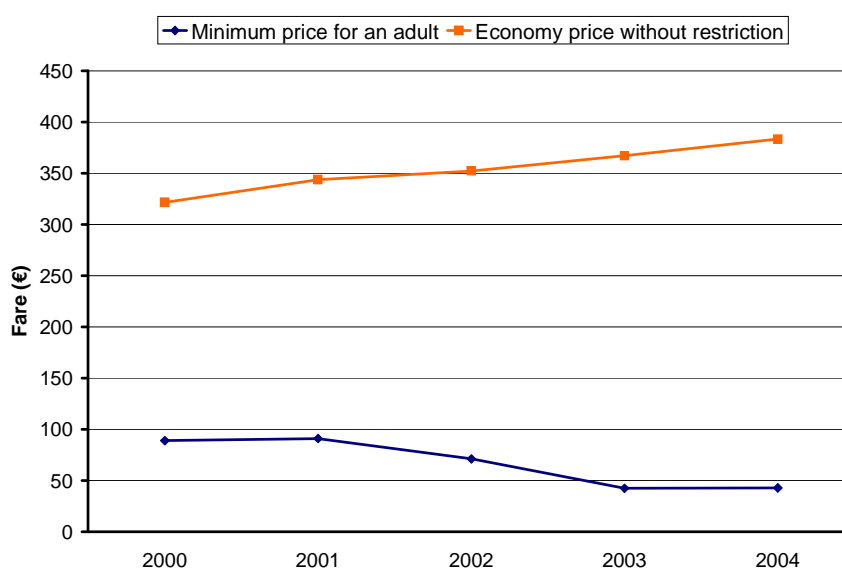

Source: DGAC

### Service quality and on-board services

- 7.30 Generally we found that the service quality offered by the TGV is better than that offered by Air France. It also appears to be more reliable.

#### On-board services

- 7.31 The TGV has a buffet bar on-board, family-friendly areas, and the facility to rent and watch DVDs. In addition the iDTGV has games consoles, magazines, packs of cards and 'sleep kits' (a pillow, earplugs and sleep-mask) available, and they have experimented with providing masseurs in the 'relaxation' carriages.

#### First class service

- 7.32 On the Paris to Marseille route, Air France only offer an economy class service. However, at present they are continuing to provide a catering service to economy passengers. A first class product is available, typically for about €25-50 extra, on standard TGV services; however, catering is not included in the price of the ticket in either first or second class. First class is also available to iDTGV passengers, although generally for a higher fare premium.

## Summary of services

**TABLE 7.5 SUMMARY OF SERVICE QUALITY AND ON-BOARD SERVICES**

	Air France	TGV	iDTGV
<b>On board service quality</b>			
Seat pitch (economy/standard class)	79cm	Not known	Not known
Catering included (economy/standard class)	✓	✗	✗
Check in baggage limit	23-32kg	✗	✗
Pre-assigned seating	✓	✓	✓
Magazine available	✓	✓	✓ (for sale)
1st/business class available	✗	✓	✓
Key differences in 1st/business class	N/A	Larger seat	Larger seat
Typical price surcharge for 1st/business class	N/A	25%	55%
<b>Airport / terminal facilities</b>			
Catering facilities	✓	✓	✓
Retail outlets	✓	✓	✓
Heated/secure waiting lounge	✓	✗	✗
Toilets	✓	✓ (for a charge)	✓ (for a charge)
Business lounge available	Frequent travellers only	✓	✓

## Punctuality and reliability

- 7.33 Route specific reliability data is unavailable for Paris to Marseille. We were, however, able to obtain figures for the percentage of all journeys arriving on time for each operator. TGV services are more punctual than those of Air France, as illustrated in Figure 7.7.

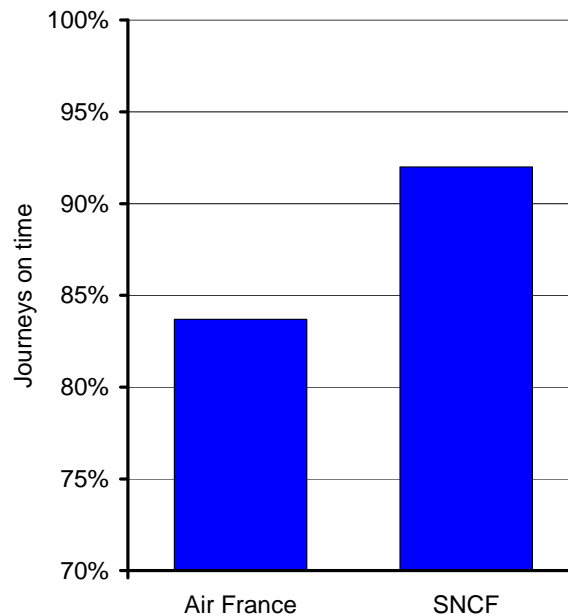
**FIGURE 7.7 PUNCTUALITY OF SERVICES**

- 7.34 Both Air France and TGV services have been susceptible to disruption caused by strikes. In the case of Air France, some of these have been caused by air traffic control rather than by their own staff. For example, recent protests against government labour policy resulted in a third of all flights and TGV services being cancelled on some days.

#### **Air-rail connections**

- 7.35 SNCF currently has codeshare agreements with a number of airlines, enabling rail tickets to be sold alongside air tickets to and from cities across France, including Marseille. This does not include the option of an integrated e-ticket; on arrival at CDG passengers exchange their flight coupon for a TGV ticket from a check-in desk.
- 7.36 An intermodal ticketing solution called TGVair has been introduced by air and tour operators for passengers travelling abroad to and from various French cities including Marseille. It essentially brings codeshare agreements under a single brand and includes a TGV return ticket between Marseille St Charles and CDG, and the international flight ticket. The solution has been set up by SNCF with a consortium of air operators, including AirAustral, Air France-KLM, American Airlines, Continental Airlines, Delta Airlines, Emirates, Lufthansa and United Airlines. No integrated baggage handling is offered, although baggage handlers are available at the TGV terminals to provide assistance – a service likely to be particularly relevant to passengers connecting to international flights who tend to have more baggage. This service costs €4.60 for one to three items, and €7.60 for four to six.
- 7.37 The location of the TGV terminal at CDG is shown in Figure 7.8 below. It is positioned between terminal 2C/D and E/F, and interchanges between rail and air at terminal 2 do not necessarily require walking further than interchanges between two

air services. Interchanges with flights using terminals 1 and 3 at CDG are less easy, as a bus journey is required.

**FIGURE 7.8 PLAN OF CDG AIRPORT (TERMINAL 2)**

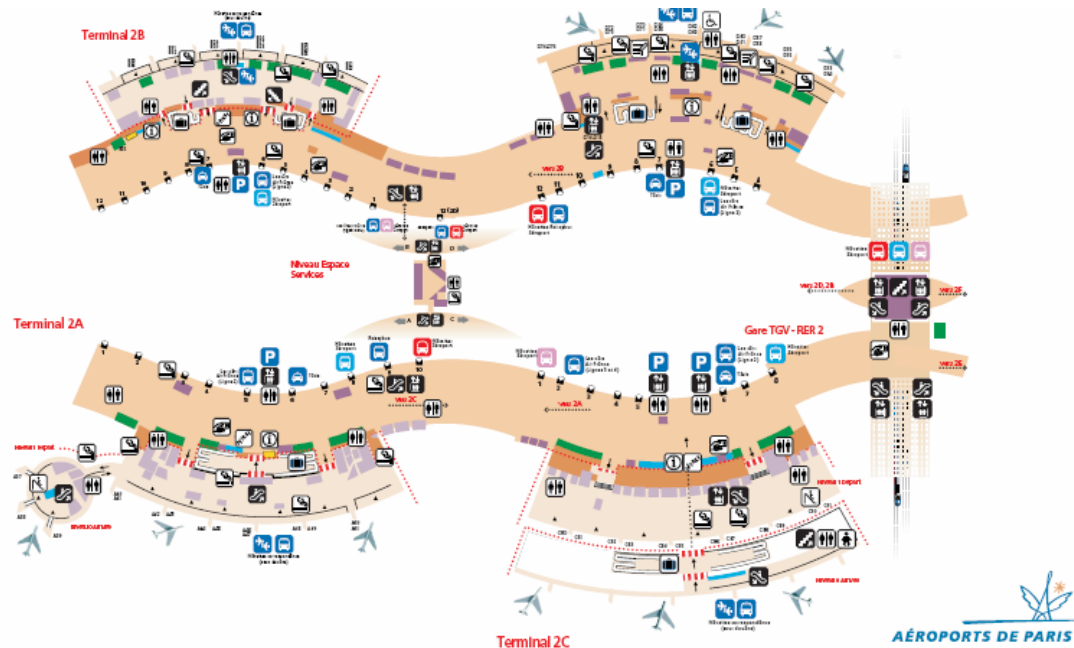

**Taxes, subsidies and regulation**

**Air**

- 7.38 The French government do not impose an obligation on Air France to provide a minimum level of service between Paris and Marseille. Fares are not regulated, and no public subsidy is provided. However, Air France does receive subsidy in order to operate other routes from the Paris airports on a Public Sector Obligation basis.
- 7.39 Airlines do not pay fuel tax but VAT of 19.6% is levied on domestic air tickets. The taxes on aviation in France are the Civil Aviation Tax and the Noise tax. The Civil Aviation Tax is charged on a per-passenger basis, and can be passed onto passengers as a separate element of the ticket price. For domestic flights (and hence for Paris to Marseille) this is €3.92 per direction – €7.84 per return fare. Noise tax is charged on the basis of Maximum Take Off Weight (MTOW) and noise classification, both properties of the aircraft type, and not on the number of passengers. Air France currently fly aircraft from the Airbus A320 family, which are charged a total of approximately €20 for each flight from Marseille, and €5 for flights from the Paris airports. Assuming Air France recoup these costs from passengers, noise tax therefore adds less than €1 to the price of a return ticket. Although there are also a range of other ‘taxes’ levied by airports for their use, including a so-called ‘airport tax’, these are not in fact government taxes, as the revenue is retained by the airport to cover its own costs.
- 7.40 Air traffic movements at Orly airport are regulated by the government, currently limited to 250,000 per year. As a result the airport is fully slot constrained. At CDG

there is no limit on slot usage, however a limitation is applied on the total amount of sound energy produced per year.

## SNCF

- 7.41 Construction of the TGV Med line was funded largely by SNCF. The government provided some direct funding, however, when costs over-ran. National rail infrastructure is now managed by the French Railways Infrastructure Authority (RFF), although some of its responsibilities are subcontracted to SNCF.
- 7.42 SNCF is a fully state-owned but legally autonomous organisation. SNCF states that its TGV services are not directly subsidised, except for a small number of infrequent trains accounting for only 1-2% of journeys. However, in total SNCF received €3.7 billion in direct public subsidy in 2004, a breakdown of which is given in Table 7.6. This figure compares to SNCF's total turnover of €22 billion in that year. Some of this subsidy covered general organisational costs such as pensions and debt payments that competing airlines, or a new entrant, would probably have to pay themselves, and therefore is an indirect subsidy to all SNCF services.

**TABLE 7.6 SNCF SUBSIDIES (2004)**

Operating subsidy	€28 million
Investment subsidy	€572 million
Pensions	€2,376 million
Debt reimbursement	€677 million
<b>TOTAL</b>	<b>€3,653 million</b>

- 7.43 The French rail infrastructure company, RFF, also receive subsidy from the government, and as this is partly to cover debt incurred on the construction of the high speed rail network, it is also an indirect subsidy to the operation of the network. In 2004 RFF levied access charges totalling €2.3 billion, whilst incurring €3.7 billion in costs. €800 million in subsidy was provided in order to reduce RFF's debt, in addition to a further €675 million in 'regeneration' subsidy. To the extent that the infrastructure (track access) charges which SNCF pay RFF do not cover costs, and that the government underwrite this shortfall, SNCF therefore receive further indirect subsidy.
- 7.44 Many of RFF's responsibilities are further sub-contracted to SNCF, in a "management subcontract". This amounted to a total of €2.64 billion in 2004.
- 7.45 Rail fares are not formally regulated, although as SNCF is a government-controlled organisation, it does face indirect political pressure not to increase fares significantly.

## Future developments

- 7.46 As the Paris-Marseille route is already entirely high speed line, except on the final approaches to the main city stations, there is no obvious scope to further improve the service by reducing journey times. Plans to further extend the TGV network beyond Marseille to the French Riviera are at the early stages of discussion and development, and this could bring Nice to within as little as 3 hours 40 minutes of Paris, potentially

increasing further the number of passengers travelling on the TGV Med. However, this would not result in any further change to market share between Paris and Marseille.

- 7.47 Restoration of Hall 2 at Paris Orly is expected to allow Air France to improve its service quality and hence competitiveness, in particular on short distance flights such as Paris-Marseille. The Hall is due to re-open in Spring 2006.
- 7.48 From July 2006, a new tax on air tickets will be applied in France in order to fund development projects. This will be €1 for European flights, and £ for international long-haul flights. It is not known whether or not Air France will pass this through to passengers as an increase in fares; to do so would further damage their ability to compete on price with the TGV.
- 7.49 Liberalisation of European passenger rail travel is currently being discussed by the European parliament, with a new regime potentially coming into force in the period 2010-2014. Air France Chairman/CEO Jean-Cyril Spinetta was recently quoted in French business newspaper, *Tribune*, as saying that when this takes place Air France could operate TGVs in its own livery.

#### **Competition from low-cost airlines**

- 7.50 Low cost airlines do compete on some other European routes where the rail journey time is less than the typical 3 hours 10 minutes on the Paris-Marseille route. However, although a service was operated by easyJet on this route, it pulled out. There are two reasons why it has been difficult in practice for low cost airlines to compete on this route:
- Slot constraints, particularly at Orly; and
  - Airport charges at the Paris airports.

#### Slot constraints

- 7.51 In order to achieve journey times that are competitive with rail, flights would ideally have to operate out of Orly airport, as it is closer to central Paris and the air journey times are shorter. In addition, there is some general evidence that passengers are unwilling to travel in the “wrong” direction to catch a short distance flight (for example from Paris to CDG in order to catch a plane to Marseille).
- 7.52 However, the severe slot constraints at Orly make it very difficult to run a viable service with sufficient frequencies. The airport is limited to 250,000 movements per year by the French government and Air France had the majority of the slots even prior to its acquisition of many of the slots made available when Air Lib ceased operations in 2003. Air France now has 62% of slots at the airport. Some of the slots are reserved for routes it runs under Public Service Obligations to particular regional airports and therefore receive subsidy.
- 7.53 As referred to above, easyJet did operate a twice-daily service between Paris and Marseille briefly, but it ceased to do so because it could not obtain enough slots to provide a competitive service: the limited slots that it has available at Orly can be used



more profitably on other routes. Given this, it is unlikely that any low-cost carrier would be able to obtain slots to fly this route in the foreseeable future. easyJet complained to the European Commission that the slot allocation procedure at Orly has unfairly favoured other carriers, particularly Air France.

#### Airport charges

- 7.54 In addition, charges at the Paris airports are relatively high. Including all taxes, per-passenger charges are around €17 for domestic flights, and if all other charges are included (landing charge, noise tax, etc), we estimate that total charges are around €21 per passenger. Although the low cost airlines have been allocated to a low service terminal at CDG originally intended for charter carriers (terminal 3), they have to pay the same airport charges. It is difficult for any low cost airline to compete under these circumstances. The lowest fares offered for the TGV – from as little as €25 each way for advance purchase tickets – cost little more than the total airport charges per passenger levied at the Paris airports.
- 7.55 There are also no alternative low-cost airports which are close enough to allow a domestic service. There is an airport at Beauvais, but it is around 100km from Paris and has no direct rail link; it is also subject to capacity constraints. The time taken to access Beauvais means that it is not a viable alternative except for longer distance routes for which there is less strong journey time competition.
- 7.56 The fact that easyJet withdrew this service is indicative of the difficulty any future low-cost carrier would have competing on the route in the future. It appears unlikely that there would be any low cost competition unless the situation with slots at Orly was resolved.

#### Conclusions

- 7.57 Our ability to undertake a detailed market study of the Paris-Marseille route has been limited, as SNCF declined to provide any information or assistance for this study. This problem was made more difficult because, compared to other European states, little rail data is publicly available in France.
- 7.58 From the data that we have available, we estimate that the TGV has achieved a share of around 67% of the total Paris-Marseille market, and 80-85% of the point-to-point market. The rail share of the total market increased from around 40% when TGV Med opened. This share is higher than has been achieved by rail operators on other European routes with comparable journey times. The relatively high market share reflects both the high quality of the rail service, and the limitations on air competition. The rail service is more comfortable and reliable than the air service, and the terminals are much better located. However, another factor which has contributed to the high rail market share is that air competition has been hampered by the lack of slots available to airlines other than Air France at Paris Orly and the relatively high airport charges levied at the Paris airports.

## 8. COLOGNE - FRANKFURT

### Introduction

- 8.1 Cologne and Frankfurt are linked by a high speed line, which opened in summer 2002. The high speed rail service, the ICE (InterCity Express), links the cities in approximately 1 hour 15 minutes. It also provides one of only two high speed rail links to a major European airport: all trains stop at Frankfurt airport, and there is also a station at Cologne/Bonn airport. The high speed rail service from Frankfurt to Cologne (and Stuttgart) are the only services in Europe where through baggage handling is offered for air/rail passengers, and this is one of only two routes where there is through ticketing between air and rail.
- 8.2 Despite the fact that the rail journey time is very short (approximately one hour from Frankfurt airport to central Cologne), and that through baggage handling and ticketing are offered via the rail service, Lufthansa has continued to provide flights between Cologne and Frankfurt. This conflicts with many standard models of air and rail market share, which would indicate that the airline would withdraw all services on a route of this length.
- 8.3 There are currently no low cost air services between Frankfurt and Cologne. However, alternative conventional rail services are available, providing a lower cost alternative to either air travel or the high speed train. In addition, it is possible to drive between Cologne and Frankfurt in approximately two hours, which may be lower cost if a group of two or more people is travelling together.
- 8.4 The objectives of undertaking this case study were slightly different to the objectives of undertaking the other case studies. There is little potential for low cost air competition between Frankfurt and Cologne and therefore the entry of low cost airlines will not significantly change the competitive situation. The main objectives of this case study are to better understand the through air/high speed rail services available at Frankfurt airport.

### Service provision

#### Journey times

- 8.5 Most high speed trains between Cologne and Frankfurt main stations (Hauptbahnhof) have a journey time of around 75 minutes, although the exact journey time varies between trains reflecting whether there are intermediate stops. Table 3.4 below summarises the rail journey times between the two main stations and the airports.

**TABLE 8.1 COLOGNE-FRANKFURT JOURNEY TIMES (VIA HSL)**

Routing	Shortest journey time	Trains per day at shortest journey time	Average journey time
Frankfurt Hbf – Cologne Hbf	01:11	3	01 :15
Frankfurt Hbf – Cologne Airport	01:11	1	-
Frankfurt Airport – Cologne Hbf	00:54	3	00:55
Frankfurt Airport – Cologne Airport	00:55	1	01:01

- 8.6 In addition, trains are available via the ‘classic’ route along the Rhine, which is more scenic but also slower, with a journey time approximately 1 hour longer. Services via this route are maintained in order to serve intermediate stations, such as Bonn and Koblenz, but also provide a lower cost alternative for Frankfurt-Cologne passengers. Trains using this route run via Frankfurt airport but do not serve Cologne/Bonn airport. Table 8.2 below summarises the rail journey times via this route.

**TABLE 8.2 COLOGNE-FRANKFURT JOURNEY TIMES (VIA RHINE ROUTE)**

Routing	Shortest journey time	Trains per day at shortest journey time	Average journey time
Frankfurt Hbf – Cologne Hbf	02:19	1	02:21
Frankfurt Airport – Cologne Hbf	02:03	1	02:07

- 8.7 Flights between Frankfurt and Cologne airport are scheduled to take 40-45 minutes.

#### Check-in times

- 8.8 It is not generally necessary for passengers to check in for Deutsche Bahn services in advance, including the ICE. However, passengers using the through rail/air services must check in 20 minutes before departure of the train. Check-in times at each airport and the rail station are summarised below.

**TABLE 8.3 CHECK IN TIMES (MINUTES)**

	Cologne station (AIRail service)	Cologne airport	Frankfurt airport
Economy class	20	30	40
Business class	20	20	30

#### Frequency and available seats

- 8.9 The number of daily trains between Cologne Hbf (main station) and Frankfurt airport, and the number of flights from Cologne airport, are shown in Figure 3.2 below. There are currently four flights per day, 32 high speed trains and 14 conventional trains. Approximately half of the high speed trains, and most of the conventional trains,

continue to Frankfurt Hbf; the remainder run south via Mannheim either towards Stuttgart or towards Switzerland.

**FIGURE 8.1 SERVICES PER DAY PER DIRECTION, COLOGNE-FRANKFURT AIRPORT**

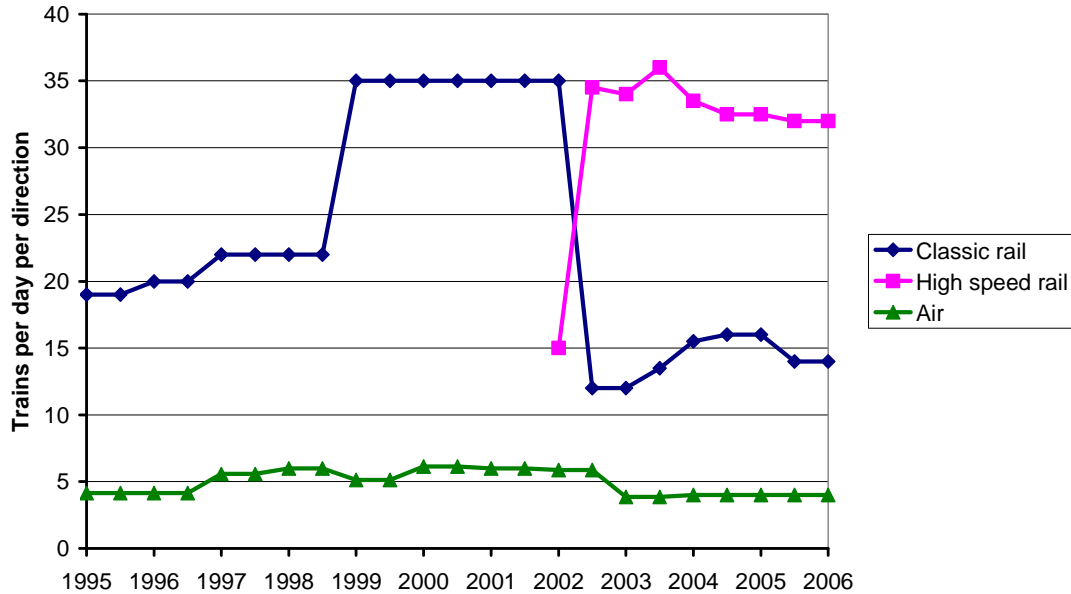

8.10 There are two main changes visible in the services from Cologne to Frankfurt:

- From 1999, many trains from Cologne to southern Germany and Switzerland were diverted to run via the new Frankfurt airport long distance train station. Previously, only trains to Frankfurt Hbf served the airport.
- The Cologne-Frankfurt high speed line opened in summer 2002, initially with an hourly shuttle service, and as a full service from winter 2002. This led to a reduction in the number of air services on the route from 6 to 4 per day.

**Market size and share**

Estimate of current market share

8.11 Analysis of market share is limited by the fact that Deutsche Bahn AG, the rail operator, does not release origin and destination specific passenger numbers, on grounds of confidentiality. Therefore, in order to estimate market share, we have used the following methodology:

- We have started with data for the capacity of the trains used on the route (440 for a single ICE train).
- The published timetable shows whether a single train or a double train is used for each service.
- Data is also available for the average load factor for Deutsche Bahn’s long distance services on the route (46.5%).
- All of the trains on the line continue to other destinations beyond Frankfurt, Cologne or both, and most of the passengers using Frankfurt-Cologne trains are

actually making other journeys (such as Düsseldorf-Basel or Cologne-Stuttgart). We have no data for this, but based on anecdotal evidence as passengers, we estimate that 40% of passengers on trains that run to/from Frankfurt Hbf are making Frankfurt-Cologne journeys, and 20% of passengers on other trains which serve Frankfurt airport only.

- 8.12 **This analysis indicates that the rail market share on the route is approximately 97%.**

Estimate of trends in market share

- 8.13 Data is not available for how Deutsche Bahn's load factor has changed over time, or for how the capacity of the trains that it used on the route has changed, so it is not possible to evaluate with any certainty how the market share has changed over time. However, the impact of the opening of the high speed line can be seen by analysis of the trend in passengers, and seats, carried on Lufthansa's air service between Frankfurt and Cologne. This analysis is shown in Figure 8.2 below.

**FIGURE 8.2 AIR PASSENGERS FRANKFURT-COLOGNE**

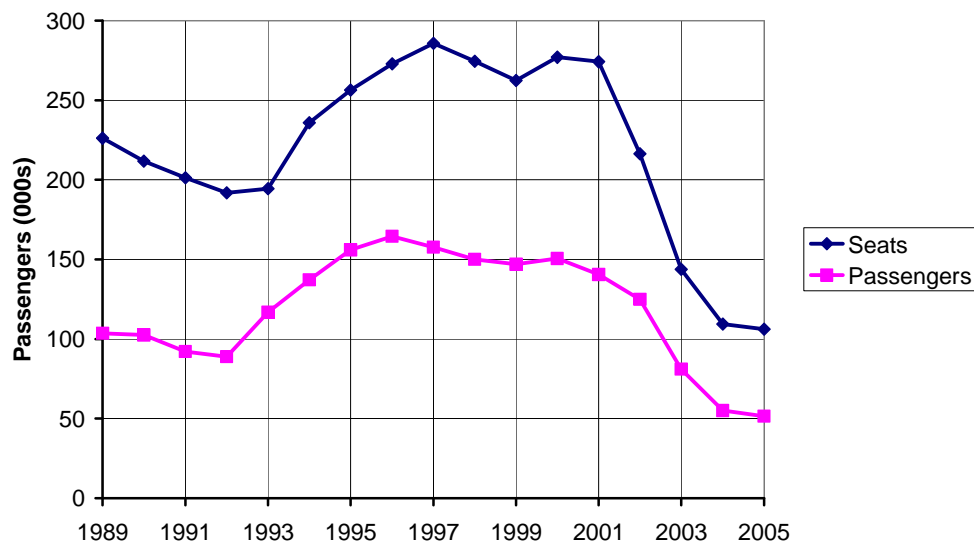

- 8.14 The opening of the high speed line between Cologne and Frankfurt resulted in a substantial reduction in the number of passengers using air services between the cities. However, the number of air passengers was falling even before the high speed line opened. This is partly as a result of 9/11 and other one-off events (such as SARS) which led to a decline in global air traffic, but the decline is greater than occurred on other routes, and therefore may also be due to the operators preparing for the impact of the new high speed line. However, it is notable that although the number of passengers handled and seats provided by Lufthansa declined substantially, the number of flights per day only reduced from 6 to 4 in each direction; part of the reduction in capacity was achieved by switching to smaller aircraft.
- 8.15 The number of air passengers was low even before the high speed line opened. Using plausible assumptions for the number of passengers using the timetabled Frankfurt-

Cologne trains before the opening of the high speed line, we estimate that the rail market share would have been 85-90% before this.

Point to point travel

- 8.16 Approximately 90% of the passengers that use the Frankfurt-Cologne air service connect onto other air services from Frankfurt. **This implies that, for Frankfurt-Cologne point-to-point passengers, the rail market share is likely to be close to 100%.** The proportion of air passengers connecting on to other air services at Frankfurt increased from about 80% before the completion of the high speed line. The number of point-to-point air passengers declined by nearly 80% between 2000 and 2005.

**FIGURE 8.3 POINT TO POINT AND TRANSFER AIR PASSENGERS**

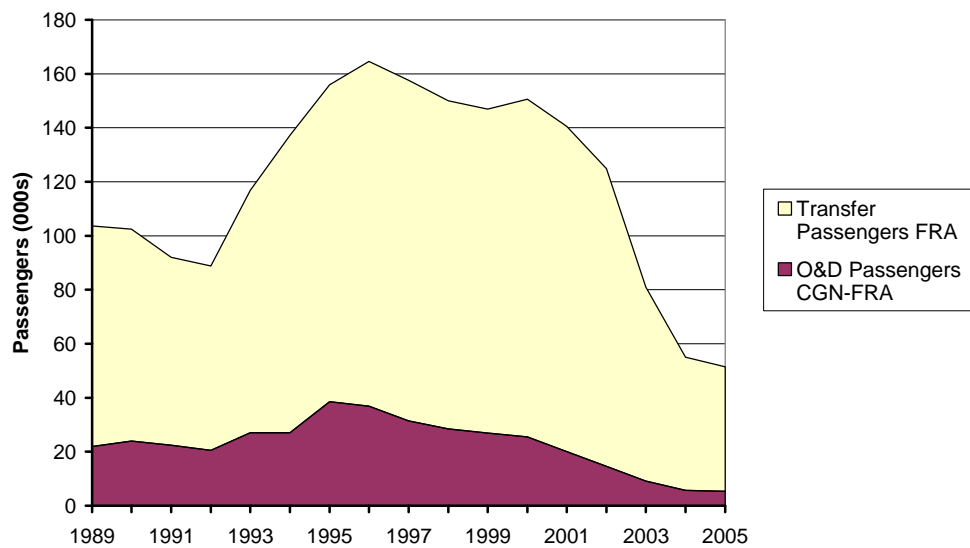

**Access to the services**

- 8.17 Both Cologne and Frankfurt airport are well served by public transport services from the cities, and driving times are relatively short, although can be affected by traffic at peak times.

**TABLE 8.4 COLOGNE / FRANKFURT AIRPORTS**

	Cologne Airport	Frankfurt Airport
Rail journey time from city centre (minutes)	14	11
Rail frequency	every 20 minutes	every 15 minutes
Rail fare (€)	2.20	3.35
Road journey time (minutes)	15	15
Car parking cost (€)	24 hours	22.50
	7 days	112.50

- 8.18 However, both Cologne and Frankfurt airports serve large metropolitan regions with several towns and cities. Cologne and Frankfurt themselves therefore account for a relatively small proportion of potential and actual demand: approximately 22% of Frankfurt airport originating passengers travel from central Frankfurt, and 35% of Cologne airport originating passengers travel from central Cologne.
- 8.19 This is reflected in the fact that high speed trains continue beyond Cologne and Frankfurt to serve a number of other stations. Some trains to Cologne stop at Deutz station within the city as well as the Hauptbahnhof, and many high speed trains continue to other cities beyond Cologne, including:
- Düsseldorf
  - Duisburg
  - Essen
  - Dortmund
  - Aachen
- 8.20 Other stations served by high speed trains beyond Frankfurt include:
- Wiesbaden
  - Mainz
  - Mannheim
- 8.21 Reflecting the dispersed nature of the population, there are other airports serving the region. Düsseldorf airport, located 47km north of Cologne, provides an alternative airport for passengers travelling to/from the north of the Cologne metropolitan area, and offers 10 flights per day to Frankfurt. Unlike the service from Cologne to Frankfurt, which mostly uses regional jets, the service from Düsseldorf uses regular aircraft including the Airbus A321, which has nearly 200 seats.

#### **Airport connections**

- 8.22 Cologne/Bonn airport and Frankfurt airport are both directly served by high speed trains.
- Frankfurt
- 8.23 There is a direct link at Frankfurt airport between the high speed rail station and the airport. This can be used by passengers either:
- as part of the through rail/air service, marketed as AIRail, which offers through ticketing and baggage handling; or
  - by taking any train to the airport and checking in for their flight there.
- 8.24 Lufthansa offers through ticketing and through baggage handling from Stuttgart and Cologne stations via Frankfurt airport to destinations on its global network, as part of through intermodal service operating under the brand 'AIRail'. The rail sector of the journey is marketed as being equivalent to an air sector, and the minimum connection time between rail and air services at Frankfurt airport is equivalent to that between air services (45 minutes). Passengers travel in dedicated coaches on board the ICE train.

- 8.25 The AIRail service uses regular scheduled ICE trains, but the service is not available on all trains. There are approximately 3 trains per hour between Frankfurt airport and Cologne but the AIRail service is only available on one train per hour. Similarly, there are two trains every two hours between Frankfurt airport and Stuttgart, but the AIRail service is only available on one service every two hours. Therefore, it may be quicker for some air/rail passengers to use regular services to the airport rather than the AIRail service.
- 8.26 The AIRail service also handles passengers travelling with Lufthansa's Star Alliance partners and some other long haul airlines operating from Frankfurt airport, including Qantas, Japan Airlines and Kuwait Airways. However, a key constraint is that passengers travelling to the USA are not permitted to use the AIRail service, because of US Federal Aviation Administration (FAA) and Transport Security Administration (TSA) requirements that airlines conduct an additional security check on all passengers before check-in. There is nothing to stop these passengers or passengers travelling with airlines that do not offer the AIRail service to use ordinary rail services to Frankfurt airport, and special discounted tickets are often available for these journeys (see below). However, these are treated as separate journeys and therefore there is no through ticketing or baggage handling.
- 8.27 There are separate stations for local and long distance trains at Frankfurt airport. The station used by local trains is closer to the airport terminal. The station used by long distance trains is approximately 500 meters from Terminal 1 (used by Lufthansa and its alliance partners), which nonetheless compares well with the distance between the airport check-in area and some of the air departure gates (the furthest gate, A42, is 1000 meters from the Lufthansa check-in). The rail station is rather further from Terminal 2, used by e.g. British Airways and Air France, and passengers must use a shuttle bus; however, 80% of passenger traffic at Frankfurt airport is handled in Terminal 1. Several airlines offer check-in counters directly at the long distance train station, so passengers do not have to carry their baggage to the terminal in all cases. Figure 8.4 shows the plan of Frankfurt airport.



FIGURE 8.4 FRANKFURT AIRPORT PLAN

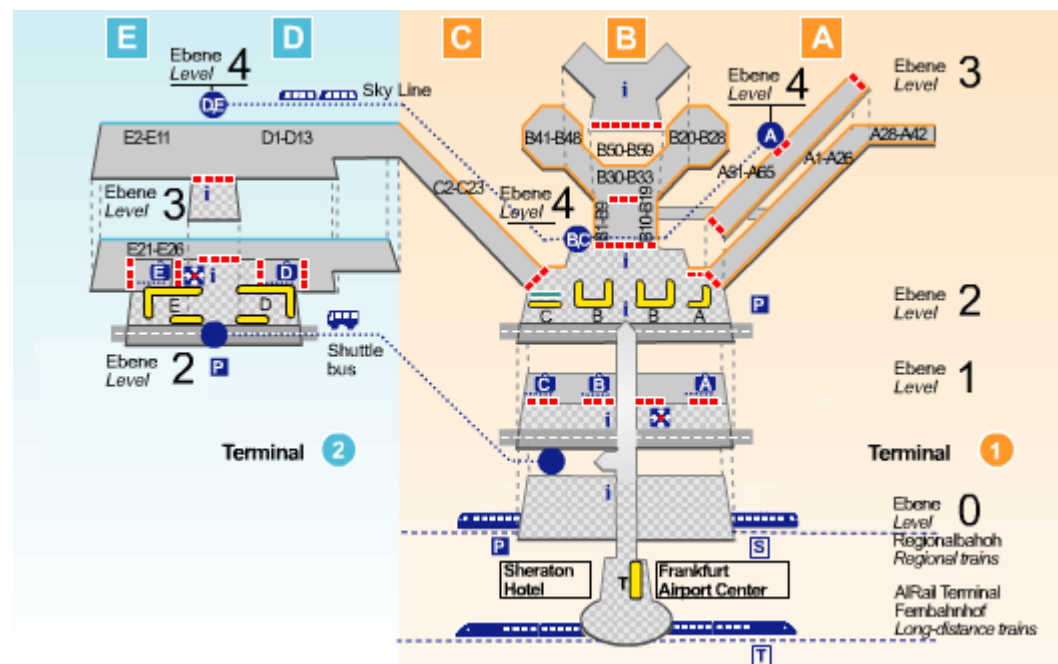

Source: Fraport

#### Cologne/Bonn airport

- 8.28 Only three of the 16 daily direct ICE trains from Frankfurt Main Station to Cologne that travel via the HSL call at Cologne/Bonn Airport. At other times, reaching Cologne/Bonn Airport from the Rhine/Main Area around Frankfurt is rather difficult.
- 8.29 Travellers between Frankfurt and Cologne/Bonn Airport have to change trains either once at Cologne/Deutz to local train S13, or twice to local train S12 from Siegburg to Troisdorf and from there by local train S13 to Cologne/Bonn Airport. The journey time is increased by these transfers on average by about 30 minutes in comparison to the three daily direct connections. In addition to the increase in journey time, the attractiveness of rail for access to Cologne/Bonn airport is further reduced by the inconveniences of the transfers at the interchange stations, as for example neither the train stations at Troisdorf or at Cologne/Deutz are equipped with escalators.

#### Fares and ticketing

- 8.30 As one of the key objectives of this case study is to evaluate the options for through air/rail travel via Frankfurt airport, we discuss separately the fares available for the following journey types:
- point-to-point journeys;
  - rail journeys to connect with flights but not as part of the AIRail service; and
  - through air-rail and air-air journeys via Frankfurt airport.
- 8.31 Lufthansa allows passengers to book over the internet and to travel with e-tickets. Deutsche Bahn tickets can also be purchased over the internet and can be printed by the passenger at home or in their office. Passengers must identify themselves with a

credit card or other card on board the train. There are no special requirements for passengers to present themselves in advance at the station but equally there is no discount for booking online.

- 8.32 Lufthansa does **not** currently allow passengers using the AIRail service to buy tickets via its website. Passengers searching for tickets at Lufthansa.com for travel from Cologne are only offered options via the Cologne-Frankfurt air services or via alternative hubs (generally Munich). It is possible to buy tickets for the AIRail service on some intermediary travel websites, including Opodo, but not others, including Expedia and Travelocity. Until recently, it was not possible to obtain an e-ticket for AIRail journeys through every distribution channel, which meant that in some instances there was an additional charge to passengers for issue of the tickets.

Prices for point-to-point journeys

- 8.33 Typical prices for air and rail travel from Frankfurt are shown in the table below. Table 8.5 shows the maximum and minimum second class/economy fares for both Lufthansa and Deutsche Bahn; we discuss the conditions associated with these fares in more detail below. The air fare is very substantially more than the rail fare, although as shown above, most air travel on the route is for journeys to destinations beyond Frankfurt, so these tickets would rarely be purchased. Passengers using the conventional train receive a discount of 35% relative to passengers using the ICE. Average fares on the route have been calculated from a range of ticket types and booking periods. These are illustrated in Figure 8.5

**TABLE 8.5 FRANKFURT – COLOGNE RETURN FARES (€)**

Condition	High speed train (ICE)	Conventional train (InterCity)	Air
<b>Travel to/from Frankfurt airport</b>			
Maximum price	110	72	418
Minimum price	55	36	108
<b>Travel to/from Frankfurt Hbf</b>			
Maximum price	106	70	-
Minimum price	53	35	-

- 8.34 In addition to the prices shown above, Deutsche Bahn often has special fares which are lower: for example, the ‘Surf&Rail’ fare, when available, can offer Frankfurt-Cologne return travel for as little as €39.

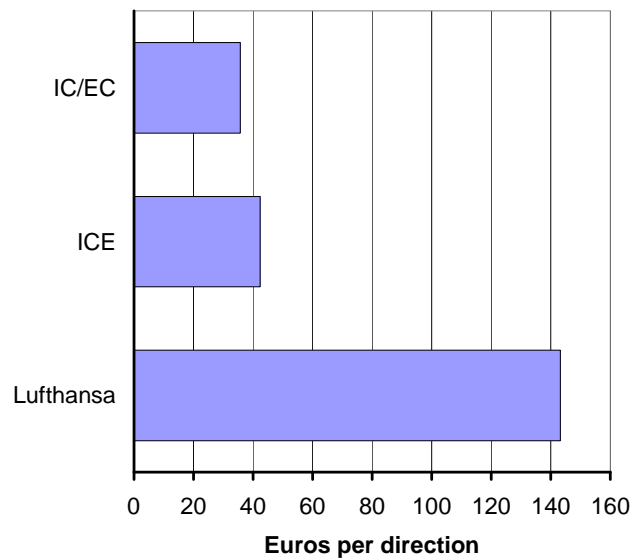
**FIGURE 8.5 AVERAGE FARES PER DIRECTION**

- 8.35 In December 2002, Deutsche Bahn introduced a new price system for long distance travel, which sought to emulate airline yield management techniques. Before this, regular rail fares in Germany had been a function of the distance travelled, the class of service and the train type; in addition to these fares, there was a wide variety of special offers. This often confused customers and even ticket agents of Deutsche Bahn, who according to a study of the consumer protection foundation “Stiftung Warentest” in 2002 only provided customers with correct information on lowest available fares on 13% of occasions<sup>4</sup>. There were some difficulties with the introduction of the new pricing system, and after some adjustments, a simplified structure was adopted. Starting from the base price for a city pair, the customer may be able to receive discounts of either 25% or 50%, subject to the conditions outlined in the table below:

<sup>4</sup> [http://hermes.zeit.de/pdf/archiv/archiv/2002/40/200240\\_bahnpreise.xml.pdf](http://hermes.zeit.de/pdf/archiv/archiv/2002/40/200240_bahnpreise.xml.pdf)

TABLE 8.6 DEUTSCHE BAHN FARE CONDITIONS

Condition	Base Price	25 per cent discounted fare	50 per cent discounted fare
Saturday Night Stay required	No	No	Yes
Advance Purchase	No	3 days	3 days
Requires return travel	No	Yes	Yes
Train use restricted to trains as booked	No	Yes	Yes
Price Floor 2 <sup>nd</sup> /1 <sup>st</sup> Class, Return	No	30 €/45 €	30 €/45 €
Rebate for group travel	No	Yes	Yes
Refund Policy	Before ticket validity – free refunds During/after ticket validity – 15 € fee	15 € before ticket validity, no refunds after validity	15 € before ticket validity, no refunds after validity
Change Fees	None	Before the day of travel: 15 € On the day of travel: 15 € plus fare differential	Before the day of travel: 15 € On the day of travel: 15 € plus fare differential
Availability	unlimited	limited	very limited

- 8.36 The Lufthansa discounted fares are less restrictive than air fares were in the past: single tickets are now available and it is not necessary to stay over a Saturday night in order to obtain a low price. The difference in price between air and high speed rail is therefore less for single trips than for other trips, as passengers wishing to make a single rail journey must buy a full fare ticket.
- 8.37 Fares for a weekend return ticket booked 2 months in advance (a typical leisure trip) and for a midweek day return booked 24 hours in advance (a typical business trip) have been collected to illustrate fare differences between the modes.

FIGURE 8.6 FRANKFURT-COLOGNE EXAMPLE RETURN FARES

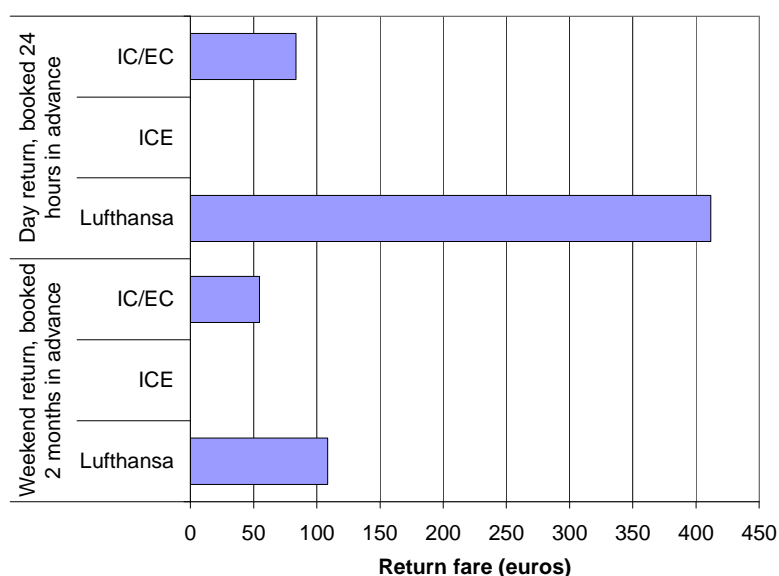

#### Prices for rail journeys connecting with flights

- 8.38 The standard offer in Germany for the use of the train to travel to the airport is the 'Rail&Fly' ticket, which is available for a number of airlines and tour operators. This ticket can be booked in connection with an air ticket and entitles the passenger to use any train between his residential location and most airports in Germany (including Basel) and, for some airlines, also Amsterdam Schiphol. The price for this service is negotiated independently between Deutsche Bahn and the tour operator or airline, and is generally €25-35 per single trip. Therefore, Rail&Fly usually offers discounts of around 50%, compared to the standard rail price between Cologne and Frankfurt. Some airlines, including China Airlines and TAP Portugal, offer Rail&Fly at no additional charge, in order to compete effectively against Lufthansa, which usually offers domestic feeder flights at little or no additional cost in connection with an intercontinental flight.
- 8.39 Although the low cost carriers which provide many of the services from Cologne/Bonn airport do not offer the 'Rail&Fly' ticket, in December 2005 low cost carrier HLX started offering a single train ticket for €19, which is marketed differently but is in practice much the same. This can be booked in connection with an international flight booked on HLX only. Although this offer is not marketed under the name "Rail&Fly", it basically features the same characteristics. It can be expected that this cooperation will prove successful, as it improves the accessibility of airports in Germany served by HLX (besides from Cologne/Bonn, international departures are offered from Hamburg, Berlin, Stuttgart, Munich, Düsseldorf and Hannover) for cost-conscious passengers, who might otherwise had refrained from using HLX simply because of the high costs involved for getting to the airport. With €38 for the return train journey, this offer features a discount of about 65% compared to the base price of Deutsche Bahn when used between Frankfurt and Cologne.

Prices for air/air or rail/air journeys

- 8.40 We have also compared prices available for through journeys via the AIRail service and connecting air services at Frankfurt airport. In most cases, Lufthansa offers the same price for a through journey via Frankfurt airport as for a point-to-point ticket from Frankfurt: the only differences are the additional taxes, fees and charges associated with the additional sector (approximately €50 return).
- 8.41 We found that, for journeys via the AIRail service, the fare offered by Lufthansa including all taxes and charges is approximately equal to the fare for the equivalent journey from Cologne using connecting air services via Frankfurt. This implies that Lufthansa avoids the additional airport charges for these journeys but that it levies an equivalent charge to cover the costs of operation of the AIRail service.
- 8.42 Until recently, air/rail journeys via AIRail were more expensive than air/air journeys when booked at several internet travel agents, because it was not possible to issue e-tickets, and therefore passengers were required to pay additional fees for issue of a paper ticket (which can exceed €20 per passenger). However, this issue has now been resolved.

Trend in prices

- 8.43 Table 8.4 shows the change in prices available on the route between 1996 and 2006. The figure shows nominal prices (without any adjustment for inflation). Fully flexible air fares have increased significantly but discounted fares, which most passengers buy, have reduced by 11%, equivalent to around 30% in real terms. Fares for InterCity trains via the conventional route have increased in line with inflation, but fares for the ICE have increased faster than this (by approximately 50%); these trains ran via the conventional route in 1996 and the increase in fares was introduced at the time of the opening of the high speed line.

**FIGURE 8.7 CHANGE IN PRICES 1996-2006**

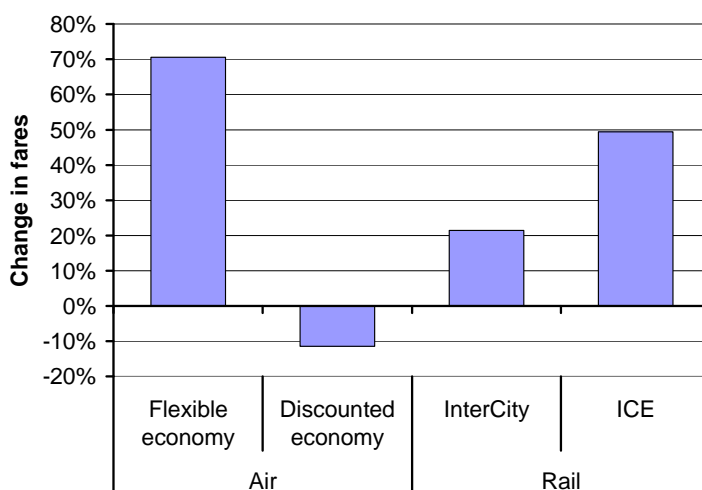

### Service quality and on board services

- 8.44 The rail service and air service offer comparable service quality. Rail offers passengers more space on board the train and luggage limits are not enforced, but on-board catering is not included, seats are not pre-assigned and facilities at stations are slightly more basic. Nonetheless, Deutsche Bahn does offer lounge facilities for first class passengers, comparable to those that might be provided by airlines. Service quality characteristics of the services are summarised in Table 8.7 below.

**TABLE 8.7 SERVICE QUALITY CHARACTERISTICS**

	Rail	Air
<b>On board service quality</b>		
Seat pitch (economy/standard class)	92cm	80cm
Catering included (economy/standard class)	No (also not included in 1st class except for AIRail service)	Yes
Check in baggage limit	1 bag, but not enforced	20kg
Pre-assigned seating	No (seat reservations available for €1.50)	Yes
1st/business class available	Yes	Yes
Key differences in 1st/business class	More space Lounge use at terminals	Better catering Lounge use at terminals
Typical price surcharge for 1st/business class	55%	20-200%
<b>Facilities at the terminals</b>		
Catering facilities	✓	✓
Retail outlets	✓	✓
Heated/secure waiting lounge	✗	✓
Toilets	✓ (but charge)	✓ (free)
Business lounge available	✓	✓
Business lounge open to all 1st class passengers	✓	✓
Local public transport	Both terminals have: local rail (S-Bahn) metro (U-bahn) local buses	Local rail services (S-Bahn) local buses

- 8.45 There is no significant difference in on-board service quality between the high speed trains (the ICE) and the conventional rail service, although the conventional trains are rather older. The only significant differences between the ICE and the conventional trains are the journey time and the price.

## Reliability

- 8.46 Deutsche Bahn states that 85% of long distance trains arrive within 5 minutes of their published time. Lufthansa states that 83% of their intra-European and domestic flights arrive within 15 minutes of their published time, while 77% of intercontinental flight arrivals are delayed not longer than 15 minutes.

## Taxes, subsidies and regulatory limits

### Railways

- 8.47 VAT is charged on rail tickets for journeys within Germany. Deutsche Bahn also has to pay energy taxes on fuel and electric power used for its operations. According to Deutsche Bahn, the taxation level it pays on electricity is €13.1/MWh<sup>5</sup>. In addition to the direct taxation for power, Deutsche Bahn is subject to shifting of opportunity costs arising from the EU-Emission Trading System for power generation companies. Deutsche Bahn estimates these costs at €50 million annually.<sup>6</sup>
- 8.48 Long distance rail services in Germany are operated by a Deutsche Bahn business unit, DB Fernverkehr. This does not receive direct state aid or subsidies for the operation of most long distance trains. However, it does benefit from grants from the federal government to Deutsche Bahn Netz AG (the infrastructure operator), to cover the costs of maintenance and renewal of the infrastructure. In theory these benefit all operators, but in practice as DB operates almost all long distance trains and all trains on the high speed line, it is the beneficiary.
- 8.49 In addition, Deutsche Bahn Holdings receives a multitude of payments, which could be considered as subsidies and have an impact on the operation of long distance trains. New projects are co-financed by the federal government in the form of grants. In addition, the government grants interest free loans to Deutsche Bahn for the construction of new railway lines. The beneficiary of these payments is Deutsche Bahn Netz, which can therefore reduce the track access prices for operators, as it does not have to bear the full capital costs of railway line construction. In recent years it was common accounting practice by DB Netz AG not to show federal grants (Baukostenzuschüsse) in the balance sheet, therefore artificially reducing the apparent cost for new projects and thereby reducing the need for depreciation in the following years. In addition to federal grants and loans, funds from the Trans-European Network (Transport) are received, as well as loans by the European Investment Bank at interest rates lower than market rates.
- 8.50 In theory, the rail operator is free to set the levels of service and fares that it wishes to provide, as if it was a commercial company. In practice, the federal government, as the sole shareholder in Deutsche Bahn Holdings, has a strong position in the supervisory

---

5

See [http://www.db.de/site/shared/de/dateianhaenge/positionspapiere/positionspapier\\_klimaschutz\\_dez\\_2005.pdf](http://www.db.de/site/shared/de/dateianhaenge/positionspapiere/positionspapier_klimaschutz_dez_2005.pdf), p. 5.

<sup>6</sup> Ibid., p. 6.



board (Aufsichtsrat) and is therefore likely to influence commercial practice, albeit informally.

#### Air services

- 8.51 VAT is also charged for domestic flights in Germany. In addition, airlines have to collect a passenger security tax which is passed on to the police, and which is intended to cover the costs of providing aviation security (for example, passenger screening). Airlines are currently exempt from fuel taxes and the emissions trading scheme.
- 8.52 Lufthansa is free to set the level of services that it wishes to provide on the route. It does not receive direct government subsidy. However, it is difficult for any other operator to enter the route because of the severe slot restrictions at Frankfurt airport. Lufthansa holds 60% of the slots and it is practically impossible for any carrier to obtain new slots at a commercially useful time. New entrants are reported to have ceased to apply for slots at the airport, being aware that there is little chance of receiving any. Therefore, there is no potential for another carrier to enter the route.

#### Potential for low cost competition

- 8.53 For most passengers, the conventional train, which is priced below the high speed train, offers a faster city-to-city journey time than an air service could. This is consistent with the finding above that the rail market share was in the range 85-90% even before the opening of the high speed line. Therefore, a low cost airline would need to offer fares below the conventional train if a service was to be commercially viable.
- 8.54 Taking this into account, there appears to be no potential for a low cost airline to enter the route. Airport charges at Frankfurt airport are too high for such a service to be viable, given the prices offered by the competing rail service. We estimate that charges at Frankfurt airport alone are around €30 per passenger for the typical type of aircraft operated by a low cost airline: this is almost as much as a discounted return fare via the conventional train, before any of the airlines' other operating costs are taken into consideration. Even if it was possible for a low cost airline to negotiate a discount on charges at Frankfurt airport for the service to be commercially viable (which appears improbable), it is unlikely that the airline would be able to obtain slots.
- 8.55 On many routes, secondary airports have allowed the entry of a low cost carrier, as these offer lower airport charges and the potential for faster turnarounds of the aircraft. However, there is no secondary airport in the Frankfurt area which could be an alternative for this route. The airport at Hahn provides an alternative for medium distance flights but it is not a feasible option for domestic flights. Hahn airport is not significantly closer to Frankfurt than it is to Cologne.

#### Future developments

- 8.56 There are only small changes planned to the nature of the service on this route. As there is already a high speed line covering the entire route between Frankfurt and Cologne, which opened in 2002, it is not practical for the rail service to be further accelerated or improved. However, as the demand for travel via the high speed line is

expected to grow, it is planned to increase frequencies to departures every 20 or 40 minutes in each direction, starting in 2007. In the Federal Transport Infrastructure Plan 2003 it was proposed to construct a high speed line south from Frankfurt airport towards Mannheim, which will improve other rail connections to the airport and may lead to more trains being operated in the future. At present however, it is uncertain when construction of this new line will start, mainly due to budget constraints.

### Conclusions

- 8.57 Rail has achieved a dominant position on the Frankfurt-Cologne route, accounting for around 97% of total passengers and nearly 100% of point-to-point passengers. Even before the opening of the high speed line, we estimate that rail had a market share of 85-90% on this route.
- 8.58 Bearing in mind minimum check-in times for the air service, rail offers a shorter journey time between Frankfurt and Cologne than the air service does. This is even before the time required to access the airport is taken into consideration. Rail fares are also generally lower than air fares on this route. In addition, the high speed rail service offers direct links to the airports in each city and, uniquely in Europe, passengers can check their bags to/from the station.
- 8.59 Despite the very high quality rail service, Lufthansa has continued to operate four flights per day from Cologne to Frankfurt airport, and it offers a high frequency service using relatively large aircraft from Düsseldorf to Frankfurt. The purpose of the air service from Cologne, and to a significant extent also the air service from Düsseldorf, is to feed the Lufthansa hub at Frankfurt. Given the relatively dispersed nature of the population in the Cologne and Rhine/Ruhr area, it is likely that a proportion of passengers find the airport more convenient than the rail station, despite the fact that air travel does not offer better journey times. A further issue is that it is impossible to book through air/rail journeys via the website of the main airline (Lufthansa) and, until recently, it was not possible to obtain e-tickets for air/rail journeys via other internet sales agents such as Opodo. It is still not possible to book air/rail journeys via many of the main internet sales agents, such as Expedia.
- 8.60 Based on our stakeholder interviews, we believe that the Lufthansa air service has been maintained for the following two reasons:
- Many booking systems (including Lufthansa's own website) cannot yet show air/rail options. Therefore, if the air option was not available, passengers seeking to make a journey such as Cologne-Singapore might not be offered any option for travel via Lufthansa on the CRS.
  - Some passengers prefer air-air services. In particular, non-European residents are less likely to choose an air-rail option, because they would often have a poor perception of rail transport in general, and because they might be less certain about what the service comprised. In addition, passengers whose ultimate destination was closer to Cologne airport than Cologne railway station would tend to choose the plane.
- 8.61 Using data provided by Lufthansa and Deutsche Bahn, it is reasonable to estimate the total number of AIRail passengers arriving at Frankfurt airport per day from both Cologne and Stuttgart at about 400 to 500. This number compares to a total of 17,500

travellers arriving at the long distance train station at Frankfurt airport per day. Using a regular train to Frankfurt airport on an ordinary ticket may be more attractive for some passengers, in part because very good deals are available (using the discounted Rail&Fly tickets), and also because the AIRail service is only available on approximately one third of trains between Cologne and Frankfurt.

- 8.62 There is no low cost air service between Frankfurt and Cologne and it is unlikely that any low cost airline would consider it commercially viable to introduce such a service in the medium term. Even if such a service could be commercially viable, it would probably be impossible for it to obtain slots at Frankfurt airport. There is no other airport in the area that offers a reasonable alternative for domestic flights. The main low cost competition to the high speed rail service is provided by road transport and the slower conventional rail service.

9. LONDON - EDINBURGH

Introduction

9.1 The London to Edinburgh route in the UK has seen strong competition between rail and air services for a long period, but the rail service now also has strong competition from low cost carriers (LCCs). easyJet provides 16 flights per day on this route, almost as many services as the largest network carrier, British Airways, or the rail operator. The route was also one of the first European routes to be served by a low cost carrier<sup>7</sup>. The effects of the LCC in this market are therefore likely to be very different from those where LCCs only operate one or two flights per day, but as LCCs continue to expand, it might be expected that more routes will acquire the characteristics of the London-Edinburgh market.

9.2 The route is not served by high speed trains as generally defined (operating at 250km/h or over), but in practice the rail service between London and Edinburgh is comparable to a high speed service in terms of both service offer and average operating speed.

Service provision

9.3 The table shows the operators currently providing services on the London-Edinburgh route.

TABLE 9.1 LONDON-EDINBURGH ROUTES

Mode/ Carrier	London	Edinburgh
<b>Classic Air</b>		
British Airways	London City (LCY)	Edinburgh Turnhouse (EDI)
British Airways	London Heathrow (LHR)	Edinburgh Turnhouse (EDI)
British Airways	London Gatwick (LGW)	Edinburgh Turnhouse (EDI)
BMI	London Heathrow (LHR)	Edinburgh Turnhouse (EDI)
Scotairways	London City (LCY)	Edinburgh Turnhouse (EDI)
<b>Low-Cost Air</b>		
Flyglobespan	London Stansted (STN)	Edinburgh Turnhouse (EDI)
easyJet	London Gatwick (LGW)	Edinburgh Turnhouse (EDI)
easyJet	London Luton (LTN)	Edinburgh Turnhouse (EDI)
easyJet	London Stansted (STN)	Edinburgh Turnhouse (EDI)
<b>Rail</b>		
GNER	London King's Cross Station	Edinburgh Waverley Station

<sup>7</sup> The only routes served by low cost carriers prior to London-Edinburgh were UK/Ireland routes served by Ryanair from the early 1990s.

## Service provision

### Journey times

- 9.4 GNER's London to Edinburgh Intercity service has an average journey time of approximately 4 hours 30 minutes. The journey time has remained fairly constant for the last decade, although has at times been as low as 4 hours 20 minutes. The fastest rail journey time is currently 4 hours 8 minutes and has in the past been as low as 3 hours 59 minutes. As discussed below, rail journey times can be much longer at weekends when the service is regularly disrupted by engineering works carried out by the infrastructure company, Network Rail.
- 9.5 Scheduled air journey time is 1 hour 25 minutes. This includes both flight time and allowances made by airlines for delays caused by congestion, particularly at the London airports.

### Frequency and available seats

- 9.6 On weekdays there are currently 40 'classic' air services, 19 low cost services and 19 direct trains. Rail services grew steadily from 17 per day in 1995 to a peak of 20 per day in 1999-2001. Air frequencies are 79% higher today than they were in 1995.
- 9.7 In 1997, the first low cost air services were launched between London and Edinburgh. easyJet initially offered 6 flights per day from Luton airport. London-Edinburgh was one of the first two routes operated by easyJet, the other being London-Glasgow. By 2005, easyJet were flying a total of 16 flights per day from Luton, Stansted and Gatwick. From 1998, easyJet faced competition from British Airways' low cost subsidiary, Go, which it purchased in 2002. More recently, a further low cost operator, Flyglobespan, has entered the London-Edinburgh, starting services from Stansted airport in 2005.
- 9.8 Classic air services are operated by British Airways from London City, Heathrow and Gatwick, BMI from London Heathrow, and Scot Airways from London City. We define BMI as a classic airline but, as noted above, it has recently adopted many of the characteristics of a low cost airline. Trends in service frequency are summarised in Figure 9.1.
- 9.9 Edinburgh can be reached from Glasgow International Airport (85km from Edinburgh city centre), and Glasgow Prestwick International Airport (130km from Edinburgh). We do not include these routes in this case study, but it is important to note that these airports would compete for market share for passengers travelling to and from areas further away from the city centre.

FIGURE 9.1 RAIL AND AIR FREQUENCY (EACH WAY)

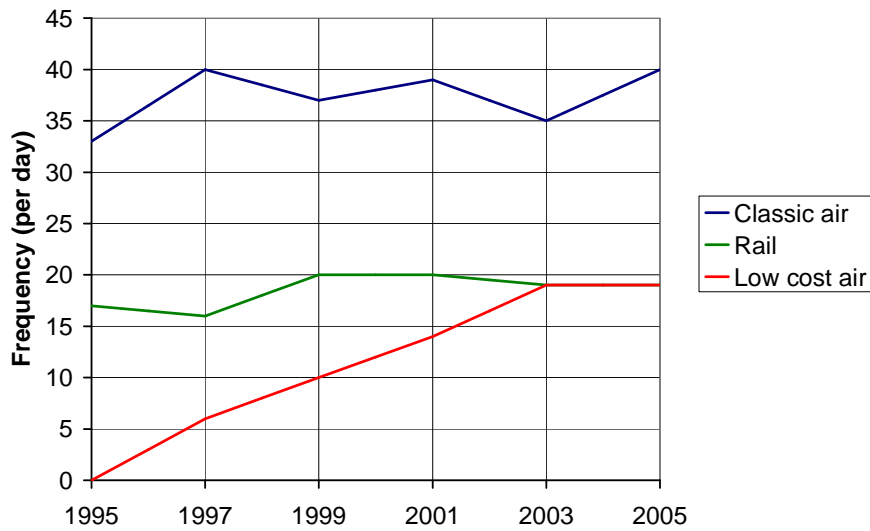

Source: Thomas Cook European Rail Timetable, OAG airline guide

- 9.10 GNER run nine-carriage trains with a total capacity of around 550 passengers on its East Coast mainline service, and therefore its theoretical London-Edinburgh capacity is far higher than classic and low cost air combined. However, trains on this route make a number of intermediate stops and much of this capacity is used for passengers travelling to/from these intermediate stops; in addition, some trains are extended to destinations beyond Edinburgh, and some capacity is therefore used for passengers travelling to these destinations.
- 9.11 Average aircraft size on the route is 127 seats, 8% lower the 1995 figure of 137. In 1995 the route was dominated by British Airways flying 757-200s from Heathrow with a capacity of about 190 seats per aircraft. In the meantime, British Airways have reduced the average size of the aircraft they operate on the route, and the main new airline, easyJet, uses 737-300s and Airbus 319s, which have a seat capacity of 149/156, even in easyJet's high density single class configuration. Trends in capacity are illustrated in Figure 9.2.

FIGURE 9.2 RAIL AND AIR AVAILABLE SEATS (TOTAL PER YEAR)

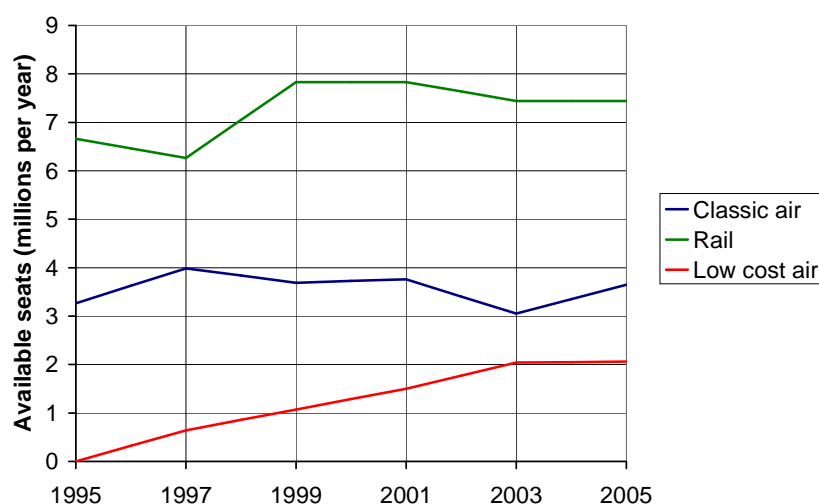

Source: Thomas Cook European Rail Timetable, OAG airline guide

- 9.12 The increase in the capacity provided by classic airlines in 2005 is due to British Airways expanding its Heathrow service from 12 to 13 flights per day, and starting a new service between London City and Edinburgh, with 5 services on each weekday.
- 9.13 As well as the GNER rail service from London to Edinburgh, there are other services from southeast England to Edinburgh operated on another route by Virgin Cross Country. These trains have significantly longer journey times but also partly compete with London-Edinburgh air services, as they serve the same catchment area.

#### Market size and share

- 9.14 The rail market share on this route declined from around 29% in 1998 to 18% in 2004. The total market for air and rail travel between London and Edinburgh grew by a cumulative 14.3% over this period, but this growth came from air travel, which increased by 29%. Rail travel declined by 21% over the same period. The trend in the number of journeys carried by each type of operator is shown in Figure 9.3 below.

FIGURE 9.3 RAIL AND AIR JOURNEYS BETWEEN LONDON AND EDINBURGH

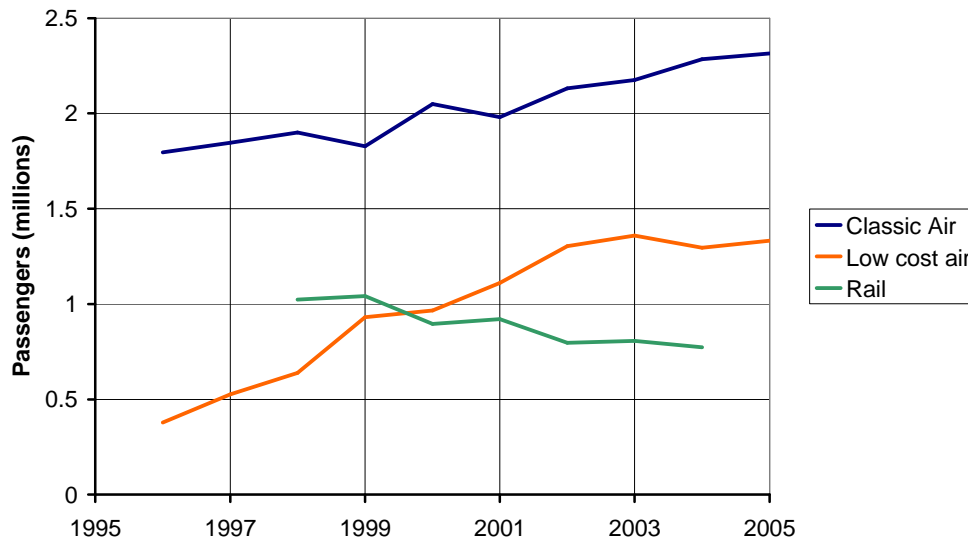

Source: CAA, SDG report, RIFF database

- 9.15 UK air passenger statistics do not show, on a route-by-route basis, which passengers are carried by low cost airlines and by ‘classic’ airlines. However, this can be inferred as they generally serve different airports in each city.
- 9.16 A key driver of demand in the London to Edinburgh market in recent years has been Edinburgh’s growth as a centre of government. The rail operator, GNER, believe that the London-Edinburgh rail service predominantly serves the leisure market, which is less time sensitive than the business market. It notes that most passengers making London-Edinburgh journeys buy ‘leisure’ tickets (lower cost, advance purchase tickets).
- 9.17 GNER also believe that the nature of the rail timetable makes it difficult for rail to compete with air for business travel between London and Edinburgh. The first train service arrives in London after 10am and the last train leaves at around 7pm. GNER see more business travellers using their service from Edinburgh travelling to Newcastle, York and to a lesser extent Leeds (which requires interchange) where this problem does not exist.
- 9.18 The business market consists primarily of bankers and government workers. In London, air offers an easily accessible service for both these sectors – for the City of Westminster (concentration of government offices) a direct rail service from Victoria station to Gatwick airport; for the City of London and Canary Wharf development (concentration of financial service offices) the Docklands Light Railway provides easy access to City airport.
- 9.19 Many of the air passengers on the route are actually connecting with other air services particularly at London Heathrow airport. There is no direct link between the train terminals and airports, and as such rail cannot compete in the market for passengers connecting onto other air services. According to CAA survey data, almost half of UK domestic airline passengers connect at either the origin or destination airport, but the



proportion of low cost airline passengers that connect onto other services is much lower. We estimate that rail has a share of around 24% of the point-to-point market, and that low cost airlines now carry almost as many point-to-point passengers as the 'classic' airlines. This analysis is shown in Figure 9.4 below.

**FIGURE 9.4 MARKET SHARE (2004)**

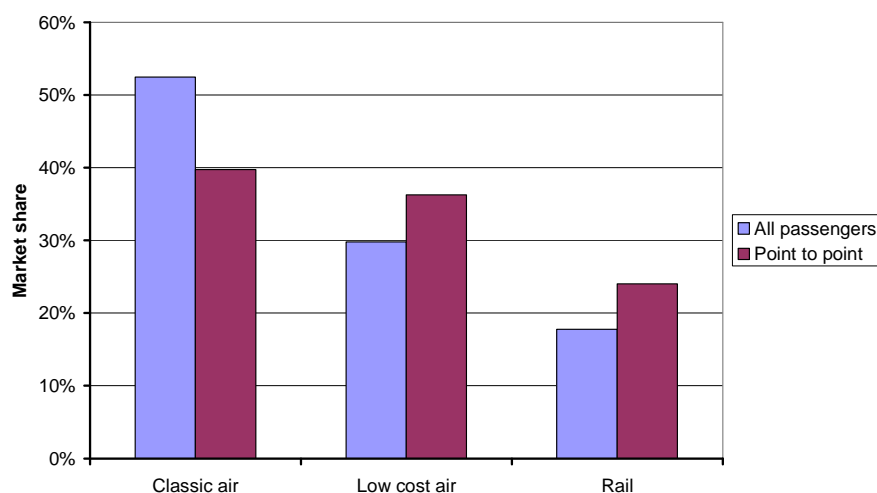

Source: SDG analysis

- 9.20 In addition, these air and rail carriers compete against coach (bus) services and private cars, especially for travel between areas away from the city centres. Bus journey times between London and Edinburgh are approximately 8 hours, much longer than journey times by rail, but there is intense competition between operators and very low fares are available.

### Access to services

#### London

- 9.21 The London passenger catchment area includes Greater London boroughs, Hertfordshire, Surrey, Berkshire, Essex, Buckinghamshire, Kent, East Sussex, West Sussex, Suffolk, Hampshire, Bedfordshire, Cambridgeshire, Norfolk, and Oxfordshire.
- 9.22 Based on CAA survey data, air travel passengers tend to concentrate in the Greater London, Hertfordshire and Surrey areas. Within Greater London, the rate of air travel is much more intense within the City of London, City of Westminster, Kensington and Chelsea, Camden, Hammersmith and Islington. The proportion of air travellers going to or coming from the City of London is relatively high, suggesting that most business travellers go directly between the airport and their place of work/ business.
- 9.23 Figure 9.5 shows the distribution of air passengers versus that of population in the air market's catchment area.

FIGURE 9.5 POPULATION AND AIR TRAVEL DEMAND DISTRIBUTION IN SOUTHEAST ENGLAND

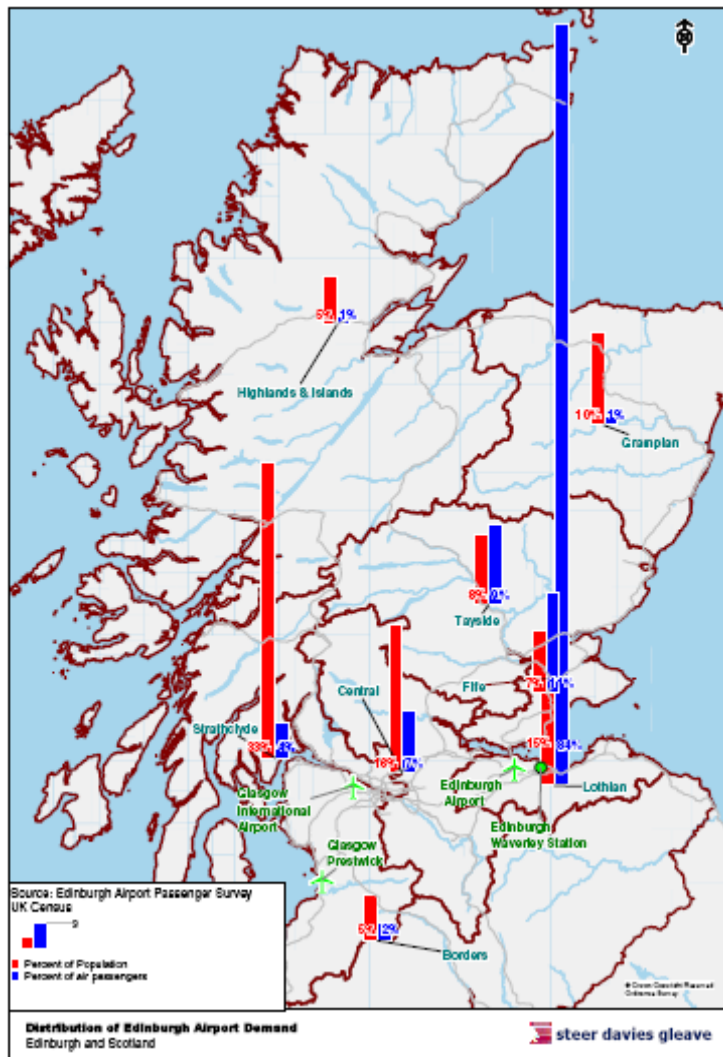

9.24 London Heathrow Airport is accessible from the city centre via rail, underground, and bus. Heathrow Express operates a quarter-hourly express rail service between Heathrow Airport and Paddington station in the city centre. Stansted, Luton and Gatwick airports are connected to London’s main rail stations (including King’s Cross station) by direct train services and buses. London City airport is located six miles away from the city’s financial district, and is accessible directly via the Docklands Light Railway and shuttle buses.

9.25 London King’s Cross station is located in the city centre, and is a hub for commuter rail, underground and bus services.

9.26 Table 9.2 shows public transport and car access times and costs to airports and train station in London. We show the following:

- Access times and costs by public transport from the city centre;
- Weighted average public transport access times, calculated by weighting access times between the centre of each origin borough to the terminal by borough

population. We further assume that only passengers living within greater London area would go to the airports by public transport; and

- Weighted average car journey times.

**TABLE 9.2 ACCESS TIMES AND COSTS TO LONDON TERMINALS**

Terminal	Access by public transport from city centre		Journey time weighted by population distribution (minutes)	Parking fess (24 hours at terminal)
	Journey time (minutes)	Cost		
Heathrow	46	£13: Heathrow Express £4: Underground	66	£43
Gatwick	44	£14: Gatwick Express £9: National Rail	72	£18.5
Luton	65	£11.5: National Rail	76	£25
Stansted	54	£15: Stansted Express	74	£20.5
City	38	£3: Docklands Light Railway	78	£20
King's Cross	n/a	n/a	66	£16

Source: TfL Journey Planner, BAA website, London City Airport website, Luton Airport website, NCP customer service. *Prices in January 2006*

- 9.27 The analysis shows that King's Cross station and City airport are significantly more accessible from the city centre, particularly by public transport. However, other airports are much more easily accessible by car; not to mention the £8 (£11) per day congestion charge in central London, which would apply to car journeys to King's Cross station.

#### Edinburgh

- 9.28 A third of Edinburgh Airport's passengers travel to or from Edinburgh City Centre. The majority of Edinburgh Airport's passengers are from the Lothian region (66%). Figure 9.6 shows the distribution of air passengers versus that of population in the air market's catchment area.

FIGURE 9.6 POPULATION AND AIR TRAVEL DEMAND DISTRIBUTION IN SCOTLAND

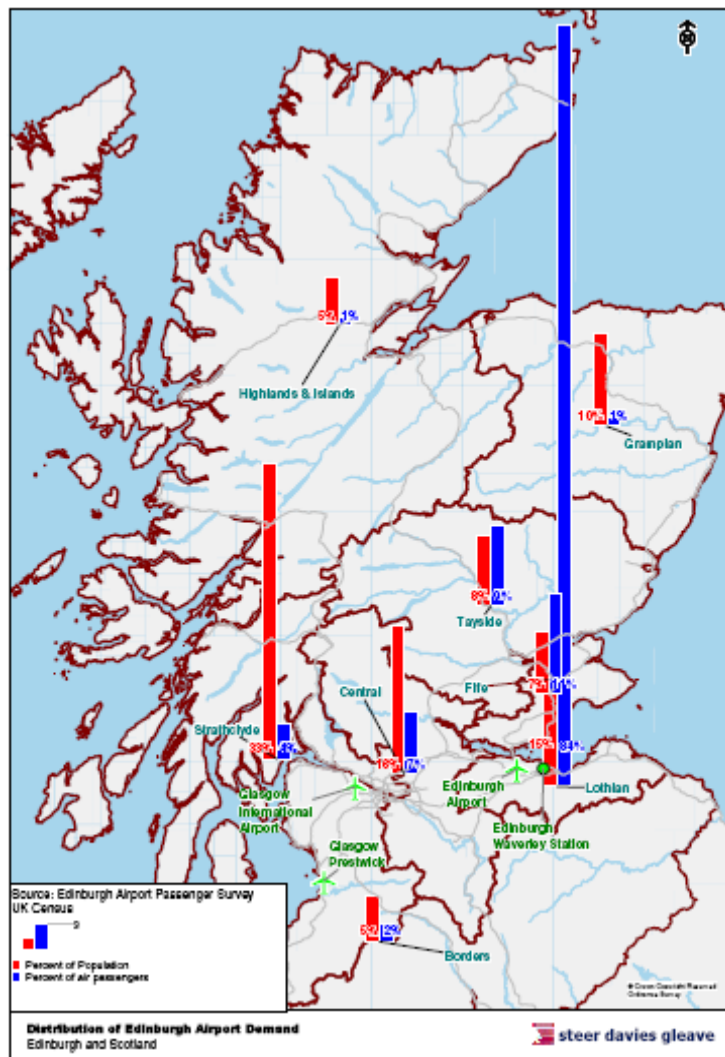

9.29 A frequent express shuttle, Airlink 100, runs between Edinburgh Airport and the city centre (Waverly station).

9.30 Similar to the analysis done for London terminals, Figure 9.6 shows public transport and car access times and costs to airport and train station in Edinburgh.

TABLE 9.3 ACCESS TIMES AND COSTS TO EDINBURGH TERMINALS

Terminal	Access by public transport from city centre		Journey time by public transport by population distribution (minutes)	Access by car (weighted by population)	
	Journey time (minutes)	Cost		Journey time (minutes)	Parking fess (24 hours at terminal)
Edinburgh Airport	25	£3: Airlink 100	106	76	£26.4
Edinburgh Waverly	n/a	n/a	83	93	£9.9

Source: www.transportdirect.info, NCP customer service. Prices in January 2006

---

### Check-in times

- 9.31 Classic airlines recommend that UK and Ireland passengers check in one hour prior to departure. The main low cost airline, easyJet, closes its check-in desks exactly 30 minutes before the scheduled departure of the flight, and late passengers would not be allowed to board the flight. They would forfeit their seat with neither refund nor free transfer. In addition, easyJet's free seating-policy and boarding procedures imply that the earlier a passenger checks in, the wider of choice of seats s/he would have on-board.
- 9.32 On-line check-in services are available to BA passengers on any ticket type (e.g. e-ticket, cardboard ticket, paper ticket). There are self service check-in kiosks at Heathrow and Edinburgh Airports (located near the standard check-in desks) for passengers flying with BMI and BA.
- 9.33 There is no need to check-in for rail journeys between London and Edinburgh.

### Airport connections

- 9.34 There is currently no high-speed rail station at any UK airport, and connections between the London rail terminal at Kings Cross and the main airports are poor:
- Passengers connecting to London Heathrow airport can use the Underground. This runs directly from Kings Cross to the airport, but the journey time is over one hour. Alternatively, passengers can connect onto the Heathrow Express rail service, but as this also requires a cross-city Underground journey to Paddington station, the difference in total journey time is not large.
  - Passengers connecting to London Gatwick airport can use the Thameslink rail service, with a journey time of about 50 minutes. This service also runs directly from Kings Cross but the connection is poor.
- 9.35 In summary, due to the poor connection, we would not expect rail to be used by a significant number of passengers from Edinburgh connecting on to other air services at the London airports.

### Fares

- 9.36 We have compared both the average level of fares, and the variability of fares and the conditions attached to them. On average, we found that rail tickets were more expensive than the tickets issued by the low cost carriers, but cheaper than those issued by the network carriers.

### Level of fares

- 9.37 We collected a large sample of fares for all operators and average fares, from our sample, are shown in Figure 9.8 below. The sample was designed to reflect a typical mix of tickets, with different advance purchase periods, degrees of flexibility, single/return tickets etc. GNER, the rail operator, levies fares that are on average more expensive than the low cost airlines but below those levied by the network carriers. The low cost airlines charged fares approximately half those of the network carriers.

**FIGURE 9.7 LONDON- EDINBURGH AVERAGE FARES, PER DIRECTION**

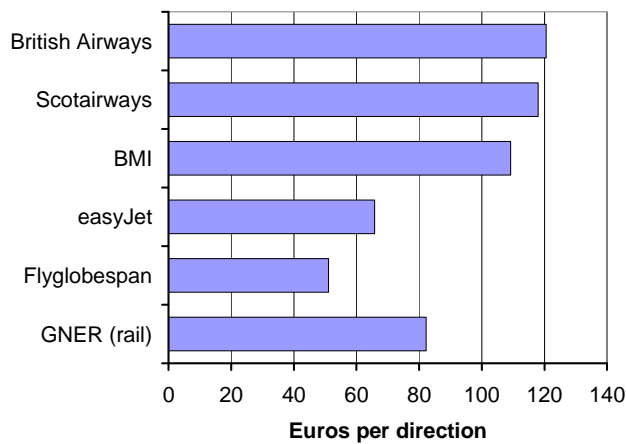

Source: Operator websites

9.38 Figure 9.8 compares fares for two specific journey types - a return journey over a weekend booked two months in advance, selecting the lowest possible fare (typical of a leisure trip); and a journey that leaves and returns to London on weekdays booked within 24 hours of departure (more typical of a business trip). The cheapest advance purchase fare was offered by the rail operator, but the airlines could be cheaper for tickets purchased at the last minute.

**FIGURE 9.8 LONDON- EDINBURGH RETURN FARES**

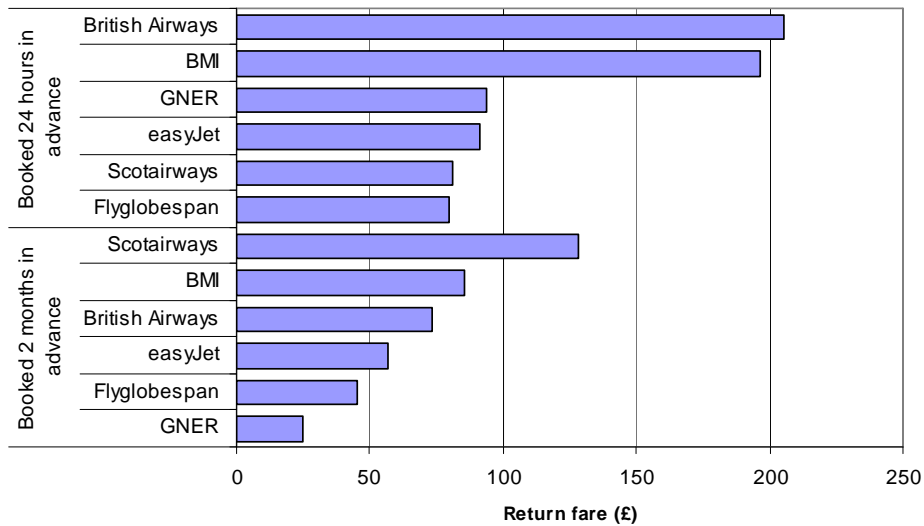

9.39 The degree of flexibility offered by some rail tickets is similar to that offered by the low cost airlines. The cheapest rail tickets available are the ‘GNER Standard Advance 1’ tickets, costing £12.50 in each direction, which are non-refundable but can be changed for a fee of £10 plus any difference in price. The tickets are issued on a one-way basis and therefore there are no conditions such as mandatory returns or Saturday night stays. However, when these tickets are not available, the other standard ticket, the ‘Saver’, must be purchased and this is always a return. Some British Airways

tickets can still only be purchased as returns but it also does not require passengers to stay over a Saturday night. For business passengers requiring full flexibility, a flexible first class rail ticket is available for £301 return, almost the same as a business class air ticket on BMI (£316).

- 9.40 The departure airport can influence the price of a plane ticket. For example, easyJet flights out of Luton airport is cheaper than those leaving from Gatwick or Stansted, and British Airways flights from London City airport cost more, on average, than those from Heathrow.

#### Purchasing tickets

- 9.41 All the operators on the route have a website through which tickets can be booked. They all also issue e-tickets collectable from the relevant terminal prior to travel. This includes GNER who offer their 'FastTicket' service from a number of stations including Kings Cross and Waverley stations.
- 9.42 All of easyJet's tickets have the same standard set of conditions attached to them: they are non-refundable, and are only valid on the specific flight for which they are sold. Changes to passenger names and flights can only be made on payment of the difference in fares, taxes and charges, and of an unspecified fee per passenger.
- 9.43 The Friday-Monday, LON-EDI journey on a non-flexible ticket on British Airways (departing from London City Airport) costs £94.10. The equivalent fully-flexible ticket would cost £363.10. Changes are permitted for no fee and any unused portion of the ticket is fully refundable.

#### Trend in fares

- 9.44 Figure 9.9 shows the changes in the costs of travel by different modes within the UK. The average fare of air travel in the UK is deducted by dividing total revenues by total passenger miles on UK airlines. As such, this index includes fares for domestic and international air travel. The real cost of air travel in the UK has dropped in the past decade, and particularly since 2001. This is due to the surge of low cost airlines.

FIGURE 9.9 UK TRANSPORT COST INDICES

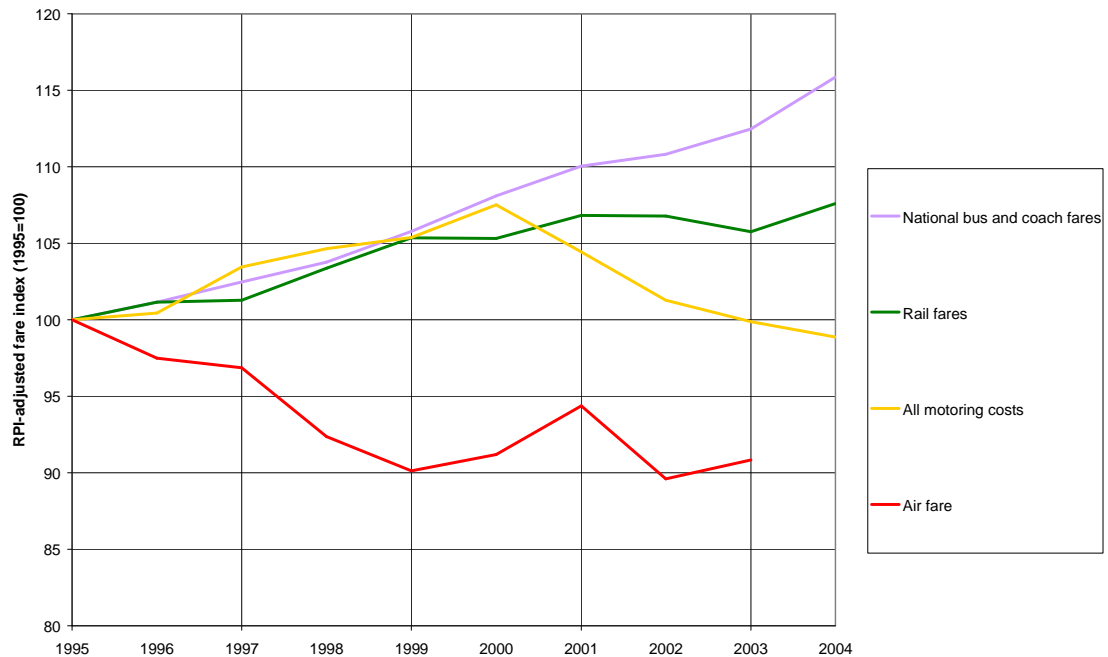

Source: Office of National Statistics, CAA airlines data

- 9.45 We do not have route-specific data on changes in fares for any of the operators. GNER informed us that, although their fares have increased on average, in response to air competition lower fares are available for the London-Edinburgh service. However, the average fare charged by the main low cost airline, easyJet, across all of its routes, was approximately the same in 2004/5 as in 1997/8, despite inflation (around 20% in total over the period) and increases in average route length of 17%. Adjusting for route length, this implies that the fares charged by easyJet declined by 5-10% in nominal terms and 25-30% in real terms over this period.

### Reliability and punctuality

- 9.46 The punctuality achieved by the three types of operators is broadly similar. However, a critical problem is that rail services often do not run at weekends, because the infrastructure company (Network Rail) closes the line for engineering work.

#### Punctuality

- 9.47 Figure 9.10 shows the punctuality of services between London and Edinburgh on the different operators. Low cost services are more reliable than the network carriers, reflecting the fact that they do not use London's Heathrow airport, which is prone to delays due to congestion. The rail operator is nominally more reliable than the air operator, but these statistics exclude regular periods of disruption due to engineering work (see below). It should also be noted that the punctuality figure for rail covers all services operated by GNER, the operator of long distance trains on the line from London to Leeds, Newcastle and Scotland, and is not specific to journeys between London and Edinburgh. GNER informed us that the London-Edinburgh service is marginally less reliable than average, reflecting the longer route length.

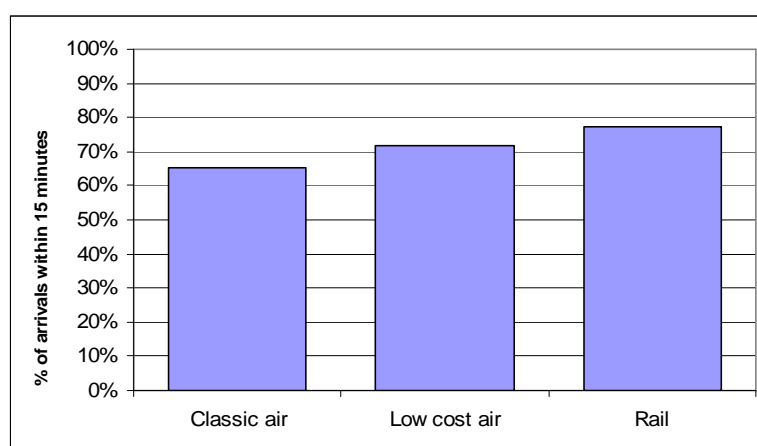

**FIGURE 9.10 PUNCTUALITY ON LONDON- EDINBURGH ROUTE (2004)**

Source: UK CAA, Rail Industry Monitor 2005

### Reliability

- 9.48 A critical problem is that rail services within the UK are prone to severe disruption at weekends due to engineering works. GNER stated that there seems to be a closure of rail services every September between Newcastle and Edinburgh, during which services are diverted and/or replaced with buses. At the time we undertook our study, there was no through London-Edinburgh rail service planned during weekends at any point in the next two months: trains were always replaced by buses for at least part of the journey.
- 9.49 When there are engineering works, journey times are extended by 1-2 hours, and tickets also tend to be more expensive, as capacity-controlled discounted fares are usually not available when a bus journey is required for part of the journey. Interchanging between buses and trains is particularly unattractive for long distance passengers who are likely to have heavy luggage. This is likely to have a significant impact on rail market share, as although rail is comparable to air for city-to-city journey time and price if the service is not disrupted, it is substantially slower, less convenient and often more expensive at times of engineering work. Even if a passenger is only planning to travel in one direction at a weekend, if the service is not running then, they are likely to travel in both directions by air or road.
- 9.50 GNER believes that the higher number of weekend closures in the UK is due to the high utilisation of the network and the limited availability of alternative routes. Alternative rail lines are not electrified and so cannot be used by regular GNER trains. In addition, particularly onerous health and safety regulation in the UK has limited the possibility of rail services being maintained at reduced speeds during periods of disruption. Other long distance rail operators have publicly complained about the “five day a week” railway and have accused the infrastructure manager of having grown accustomed to closing lines at weekends as a matter of course.
- 9.51 A further issue that has contributed to the decline of rail market share is that a number of major accidents between 2000 and 2002 led to disruptions of GNER services. Most significantly, an accident at Hatfield in October 2000, involving a high speed GNER

train, resulted in major disruption across the UK rail network, including substantially extended journey times for a long period, and a large number of route closures.

### Service quality and on board services

9.52 The following table compares various service quality characteristics for the different modes, and the terminals that they serve.

**TABLE 9.4 SERVICE QUALITY AND ON-BOARD SERVICES**

	Rail	Classic airlines	LCC
<b>On-board service quality</b>			
Seat pitch (economy/ standard class)	Designed to accommodate 188-cm tall passengers	79-81cm	72-73cm
Catering	Refreshments for 1 <sup>st</sup> class passengers only	√	X
Check-in baggage allowance	No weight limit, but operator reserves the right to charge extra for passengers carrying more than three large items of luggage	15kg- 32kg; £5/kg- £15 flat rate for excess luggage	20kg; £5/kg for excess luggage
Pre-assigned seats	√	√	X
Magazines and newspapers available	X	√	X
1 <sup>st</sup> / business class available	√	√	X
Key differences in 1 <sup>st</sup> / business class	Complementary refreshments	Higher luggage allowance; use of business lounge	n/a
<b>Airport/ Terminal facilities</b>			
Catering/ dining facilities	√	√	√
Retail outlets	√	√	√
Heated/ secure waiting lounge	X	√	√
Toilets	√	√	√
Business lounge	√	√	√

9.53 easyJet is the only airline on the route with no complementary offer; and while GNER have the most extensive catering facilities on board their trains, they only offer complementary refreshments to their First Class passengers.

9.54 The most significant additional on-board service on the route is offered by GNER. Their new fleet of re-fitted Mallard trains are equipped with Wi-fi facilities enabling passengers to connect to the internet whilst travelling. Rates for standard class passengers range from £2.95 for 30 minutes to £9.95 for 3 hours; the service is provided free of charge for First Class passengers. GNER also have a 'Quiet Coach'

available for passengers not wanting to be disturbed by mobile telephones and other electronic devices.

- 9.55 All of the London terminals have basic facilities including toilets, cafés and car parks. Although they all have cash and foreign currency facilities none of them have banks on-site, although there are banks in the local vicinity of Kings Cross. London City airport is unique in not having a 1<sup>st</sup> or business class lounge, but the standard of facilities in the regular lounge is comparable to 1st/business class lounges at other airports.
- 9.56 Access to local public transport services varies from terminal to terminal. The Heathrow Express and Docklands Light Railway give Heathrow and City airports respectively particularly good access; however, King's Cross' position at a key location on the tube network and with connecting local rail services makes it the most appealing terminal from this perspective. King's Cross also offers the best access to local bus services.

### **Taxes and subsidies**

#### **Railways**

- 9.57 Rail operators in the UK are subsidised by the UK government both directly and indirectly. Rail operators, such as GNER, bid for franchises to operate specified levels of rail services, and the operator asking for the lowest level of subsidy is generally granted the franchise. However, reflecting the relatively profitable nature of its services, rather than receive a subsidy, GNER pays a premium to the Department for Transport (DfT).
- 9.58 The DfT also indirectly subsidises all UK rail services by making direct payments to the infrastructure company, Network Rail. Although it is not possible to relate these payments directly to any individual route, only around half of Network Rail's costs are covered through the infrastructure charges levied on rail operators.
- 9.59 Rail operators do pay fuel tax in the UK, but the fuel trains use is low-grade diesel and is subject to a low level of taxation. Most trains on the London-Edinburgh route are in any case electric.

#### **Airlines**

- 9.60 There is no value-added tax imposed on air or rail travel in the UK, and airlines do not pay fuel tax. UK airlines are not subsidised, and most airports in the UK are privatised and so do not receive any subsidy. However, the UK government levies a tax of £5 on all flights from UK airports (Air Passenger Duty).

### **Regulatory limits**

#### **Rail**

- 9.61 Some UK rail fares are regulated. As well as short distance commuter fares (which are irrelevant for a route such as this), off-peak long distance flexible return tickets (known as the 'Saver' ticket) are constrained not to increase by more than inflation

plus 1%. These tickets typically account for about 30% of passengers on long distance routes. All other fares are unregulated and train companies are free to set these according to normal commercial considerations. Most UK long distance operators, including GNER, have introduced lower priced discounted tickets, which are below the level of the 'Saver' fare, in response to competition from bus operators and airlines. GNER informed us that these were now the most popular fare types on the London-Edinburgh route. The regulated Saver fare, however, effectively acts as a cap on the price of other tickets, because Saver tickets have to be available for all off-peak journeys.

9.62 GNER perceives that a key constraint is that it cannot introduce new fares quickly. They can only be introduced at specific points in the year (January, June and September). It believes that this can restrict rail operators' ability to respond to changing market conditions.

9.63 The level of service provided by rail operators in the UK is defined in the franchise agreement. Operators are generally free to run additional services if they want to, but in practice this rarely occurs, because it is either not profitable to do so, or because the infrastructure is capacity-constrained.

#### Airlines

9.64 Air fares within the UK are deregulated in line with Council Regulation (EEC) 2409/92. The UK Civil Aviation Authority does not require airlines to file these fares.

#### Future changes

##### Rail

9.65 No substantial service changes are planned for the London-Edinburgh route. GNER was awarded a seven-year franchise to operate its East Coast Mainline service starting May 2005 and as part of this, it committed to various relatively minor service improvements, including:

- Upgrading the older trains to the standards of the newer trains;
- Improvements to stations and accessibility for disabled customers and enhanced security;
- Providing additional car parking spaces at stations; and
- Achieving 90% punctuality target by 2010.

9.66 Take-up of GNER's onboard Wi-Fi (wireless internet) service has been good, and this is seen as one of the key drivers of First Class travel (where wi-fi is provided for no extra charge); GNER will install this on all trains where it is not currently available. GNER also plan to develop their first class offer, tailored particularly to the business market. Quiet coaches are also available, which appeal to passengers wanting to work without being disrupted by mobile telephones etc.

*Air*

- 9.67 No significant changes are expected to the air services provided on the route. In the long term, the construction of a third runway at London Heathrow airport may lead to additional capacity being available for domestic services and greater competition, but this is not expected until at least 2020.

**Conclusions**

- 9.68 The London-Edinburgh route was one of the first domestic routes within a European state to be served by a low cost airline. easyJet now provides almost as many services on this route as the largest network carrier, British Airways. As low cost airlines expand their services in other European states, other routes may experience changes in market share similar to those which have been seen on this route.
- 9.69 Although the rail service is not high speed (defined as trains running at 250km/h or over), it is comparable to some European high speed routes in terms of the average speeds achieved. In 2004, rail had a market share of approximately 18%, and a share of 24% amongst point-to-point passengers (excluding those connecting to other air services). Rail market share has declined significantly since 1998 and is low in comparison to some other European routes with comparable journey times, despite the fact that the London airports are generally rather distant from the city, and that surface access to airports is expensive.
- 9.70 The decline in rail market share since 1998 is due to two main factors:
- **Competition from low cost airlines:** In 1998, low cost air services were infrequent and only operated from Luton airport, the least well located of the five London airports. There are now frequent low cost air services from three London airports to Edinburgh. At the same time, airline fares have declined in both real and nominal terms, whilst average rail fares have increased. The classic airlines have cut their fares in order to compete with the low cost airlines, and this has also strengthened their position relative to rail.
  - **Disruption to rail services:** Long distance rail travel declined in the UK after the Hatfield rail accident in 2000, as journey times were extended and services were subject to severe disruption. Although the reliability of rail services has now improved significantly, some of the loss of traffic may have been permanent, and services are still subject to regular disruption at weekends due to engineering work. At the time of our study, there was not planned to be any through London-Edinburgh trains at all during weekends for the next two months – and this is not unusual.
- 9.71 Even before low cost airlines started to operate on this route, the rail market share was lower than on some continental European routes with equivalent rail journey times (around 4 hours 20 minutes – similar to Paris-Marseille prior to the opening of TGV Med). In part, this reflects the fact that most passengers using air services from London do not travel to/from central London but from the suburbs or from smaller towns within southeast England. For these passengers, air services are generally much more convenient, as there are five airports located around the city. In addition, UK air fares have historically been low compared to air fares in some other states, as a consequence of the earlier deregulation of the UK domestic market.

## 10. LONDON-MANCHESTER

### Introduction

- 10.1 The West Coast Mainline (WCML), linking London to Manchester, forms an integral part of the UK rail network. London to Manchester rail services are operated by Virgin West Coast, part of the Virgin Rail Group. Following the privatisation of Britain's railways, Virgin won a franchise in 1997 to operate West Coast mainline services (including the London Euston to Manchester Piccadilly route) for a 15-year term. The franchise agreement included plans for a two-stage upgrade to the WCML, scheduled for completion in 2002 and 2005 respectively.
- 10.2 Delays and substantial cost overruns led to the upgrade being de-scoped, which in turn resulted, in 2003, in a renegotiation of Virgin's contract. The business is now run under an ongoing management contract. Stage one of the upgrade (the stage primarily affecting London-Manchester services) was completed in September 2004, allowing the operation of 200km/h services.
- 10.3 The route is served by air from four of London's five airports (at present there are no flights between Luton and Manchester). These services are operated by both low-cost and classic airlines. Services on the route are summarised in Table 10.1.

**TABLE 10.1 SUMMARY OF LONDON-MANCHESTER SERVICES**

Operator	Type	Route
Virgin	Rail	London Euston-Manchester Piccadilly
Jet2	Low cost air	Gatwick-Manchester
Air Berlin	Low cost air	Stansted-Manchester
British Airways	Classic air	Heathrow-Manchester
British Airways	Classic air	Gatwick-Manchester
bmi	Classic air	Heathrow-Manchester
VLM	Classic air	City-Manchester

- 10.4 Air and rail services also face significant competition from private cars and coaches between London and Manchester. The two cities are well connected by the UK motorway network, and are only 320km apart by road.

### Service provision

#### Journey times

- 10.5 Typical rail journey time from London Euston to Manchester Piccadilly during the week is currently 2 hours 20 minutes, with the fastest services taking just 2 hours 10 minutes. This has fallen significantly following the completion of a key stage in the West Coast Mainline upgrade programme which allowed the introduction of tilting 200km/h services in September 2004.

- 10.6 Prior to this, engineering works had been contributing to a steady year on year increase in journey time. The typical timetabled journey time in 1995 was 2 hours 35 minutes, which by 2004 had risen to 2 hours 50 minutes. Rail services also suffered from poor punctuality, as outlined later in this case study, resulting in many actual journey times being longer than the timetable suggests. The trend in rail journey time is illustrated in Figure 10.1. At certain times, journey times have been significantly longer than this, as part of the route was closed and passengers were diverted to other routes or bus services.
- 10.7 Scheduled air journey time is 1 hour, which will include allowances made by airlines for congestion, particularly at the London airports.

**FIGURE 10.1 RAIL JOURNEY TIME**

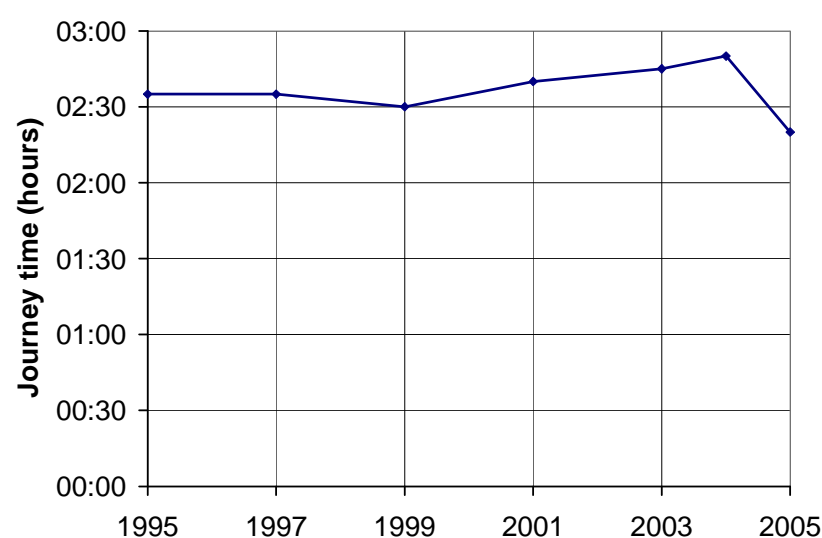

Source: Thomas Cook European Rail Timetable

#### Frequency and available seats

- 10.8 On weekdays there are currently 36 classic air, 3 low-cost air, and 32 rail services operated per day. This represents a significant increase over the past decade. Since 1995 classic air and rail frequencies have each increased by approximately 80%, and new low-cost services have been introduced.
- 10.9 Prior to 1998 British Airways was the only airline scheduling flights between London and Manchester. In March 1998 bmi introduced a service from Heathrow, operating nine flights per day, and in the same year Air UK began flying from City airport. In the years that followed bmi reduced its service to the current level of seven flights per day; Air UK ceased operating on the route in 2000 when, under the ownership of KLM, it was re-organised and re-branded.
- 10.10 VLM introduced its London City to Manchester route in September 2002, initially with five flights per day, but subsequently rising to eight. In March 2003 Eastern Airways took over British Airways' services from Stansted, flying three times per day, but later axing the route and being replaced by low-cost carrier, Air Berlin. Jet2.com

began its low-cost service from Gatwick airport in September 2004 and are currently the only other low-cost airline operating on the route. Service frequencies are summarised in Figure 10.8.

**FIGURE 10.2 EACH-WAY SERVICE FREQUENCY**

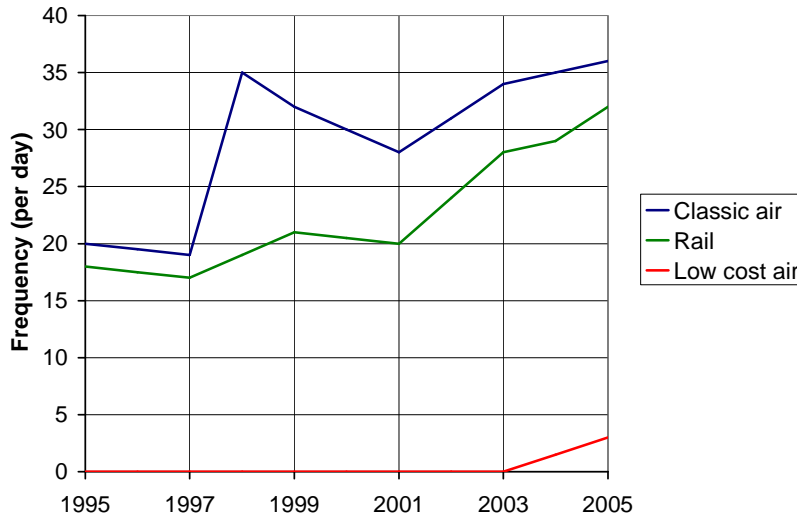

Source: Thomas Cook European Rail Timetable, OAG airline guide

- 10.11 Although rail has a lower service frequency, it has a much higher capacity in terms of number of available seats per year. In 2005 Virgin Trains introduced new Pendolino trains with a capacity of approximately 420 passengers; the previous trains had a similar capacity. Although trains make intermediate stops on the route, and so not all of the capacity is used by passengers travelling between London and Manchester, the intermediate stops on this route are not particularly significant.
- 10.12 Since 1995, average aircraft size for London to Manchester has decreased by approximately 20%, from 152 to 122 seats. Ten years ago British Airways flew Boeing 757s and 737s on its main Heathrow and Gatwick routes, with capacities of 190 and 140 respectively. Its 757s have been replaced by Airbus A320s which carry around 150 passengers (depending on the exact configuration). Although BMI also operate larger A321s, the other airlines on the route have smaller regional aircraft such as VLM's Fokker 50s with a capacity of only 50 passengers. Figure 10.3 illustrates seating capacity, in particular how the decrease in aircraft size has cancelled out much of the effect of increased frequency for classic airlines.



FIGURE 10.3 AVAILABLE SEATS (TOTAL PER YEAR)

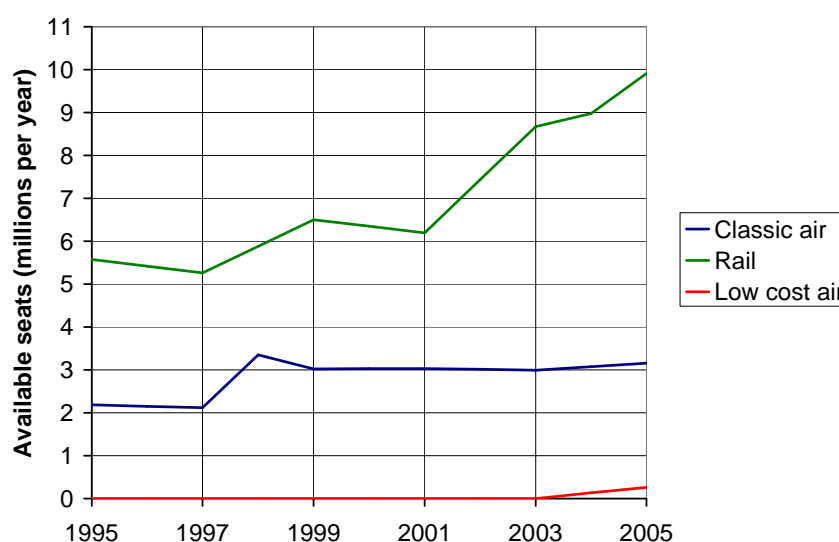

Source: Thomas Cook European Rail Timetable, OAG airline guide

- 10.13 The information on rail service frequency and journey times given above are for weekday travel. However, since 1999 there has been severe disruption to weekend services, caused by the long-term engineering works upgrading the line. Line closures resulted in replacement bus services, increasing journey times significantly. In addition, at certain periods, the line was closed during the week.
- 10.14 As well as direct trains from central London to central Manchester (London Euston to Manchester Piccadilly), there are regular fast trains from London to other areas within the catchment area of Manchester airport, including Stockport, Crewe and Warrington. There are also some direct trains from other parts of southeast England to Manchester. These areas are also within the catchment area of the London airports and therefore, as discussed below, passengers using these services should also be included within our definition of the London-Manchester market.

#### Other operators

- 10.15 The rail operator, and the other operators, face competition from low price coach services such as Stagecoach's 'Megabus', which offers fares as low as £1.50 (€2.20) each way for the London-Manchester route. The impact of these on Virgin's business is expected to be relatively limited, because such services are targeted at very price-sensitive leisure passengers that would generally travel by bus rather than by train in any case. The private car is more likely to be used by business travellers, and the operator therefore considers this to be a more serious threat.

#### Market size and share

- 10.16 The total market for air and rail travel between London and Manchester grew by a cumulative 12% over the six years between 1998/99 and 2004/05. However, this growth has predominantly come from increased air travel. Air travel increased by 31% during this period, partly countered by a reduction in rail travel by 4%. However, by

2004/5, rail still had a market share of 60% on the route.

10.17 Rail journey time and frequency improved significantly in late 2004. This led to improvements in rail market share from 60% to 68% in 2005/6, although this is still no better than it was in 1998/9, prior to the engineering works.

10.18 Publicly available air passenger data does not state the proportion of traffic carried by low cost and classic airlines, but low cost airlines on this route only operate from Stansted and Gatwick Airports in London, and therefore the proportion can be inferred. We attribute all traffic from Stansted Airport to low cost carriers, and infer the number of trips on low cost carriers low cost and “classic” carriers from/ to Gatwick Airport based on average service frequencies and loadings.

**FIGURE 10.4 AIR AND RAIL TRIPS BETWEEN SOUTHEAST ENGLAND AND MANCHESTER AREA**

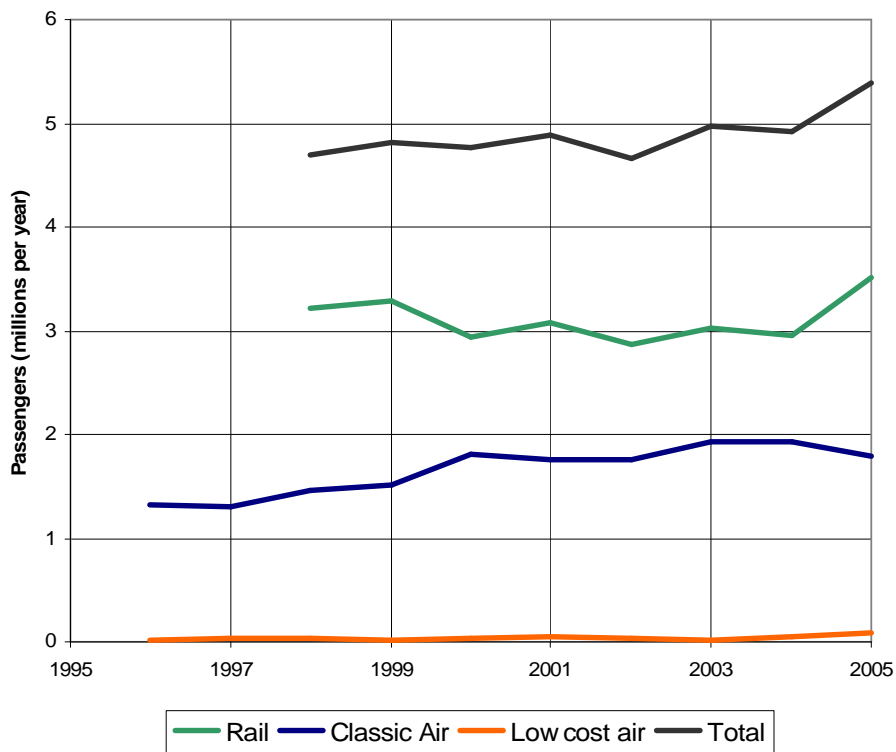

Source: CAA, RIFF, Virgin Trains, SDG Analysis

Definition of the market

10.19 It is important to understand that market share depends on how the market is defined. This is particularly important on a route such as this when there are direct rail services between a number of stations within the catchment areas for Manchester airport and the London airports, other than just the main stations (London Euston and Manchester Piccadilly).

10.20 Figure 10.5 illustrates this. The simplest definition of London-Manchester would be from the main station in London to the main station in Manchester only, and this is the data that would be provided for ‘London-Manchester’ passengers in the rail operator

revenue and passenger data system. However, many passengers make journeys from stations in other parts of London, or outside London, to stations around Manchester or to surrounding towns/cities. If we define London-Manchester as all travel from a broad area of southeast England to all of Manchester and the area around it, then rail market share in 2004/5 was substantially higher (60% compared to 45%).

**FIGURE 10.5 RAIL MARKET SHARE (2004/5), WITH DIFFERENT GEOGRAPHICAL DEFINITIONS OF RAIL CATCHMENT**

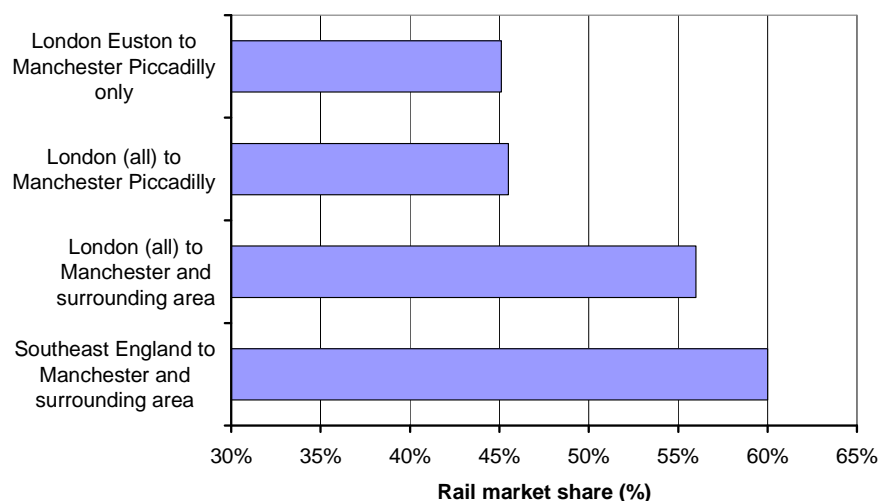

- 10.21 We have defined the rail catchment area as broadly as possible, as this is most comparable to the passenger figures available for air transport. Our definition includes any rail trip where the equivalent journey, if made by air, would have used Manchester airport and one of the London airports. Therefore, for example, we include trips such as Brighton to Warrington, as a passenger making this trip by air would fly from London Gatwick to Manchester and therefore would be defined as a London-Manchester passenger in the airport statistics. However, we do not include Southampton-Manchester rail passengers in our definition of the market, as these passengers would use Southampton airport if they travelled by air, and therefore would not be counted as London-Manchester passengers in the airport statistics.
- 10.22 In addition, our calculation of market share depends on whether we include passengers transferring to other air services at either London or Manchester, or just point-to-point passengers. The market share figures shown above applied to the whole market, i.e. included transfer passengers. However, due to the lack of a direct air link at the Manchester and London train terminals, rail cannot really compete for transfer passengers. According to CAA 2003 Survey data, 56% of UK domestic passenger traffic is point-to-point, whereas the rest are transfer journeys from either end. We estimate that rail had a 73% share of the point-to-point market in 2004/5.

FIGURE 10.6 MARKET SHARE (2004/5)

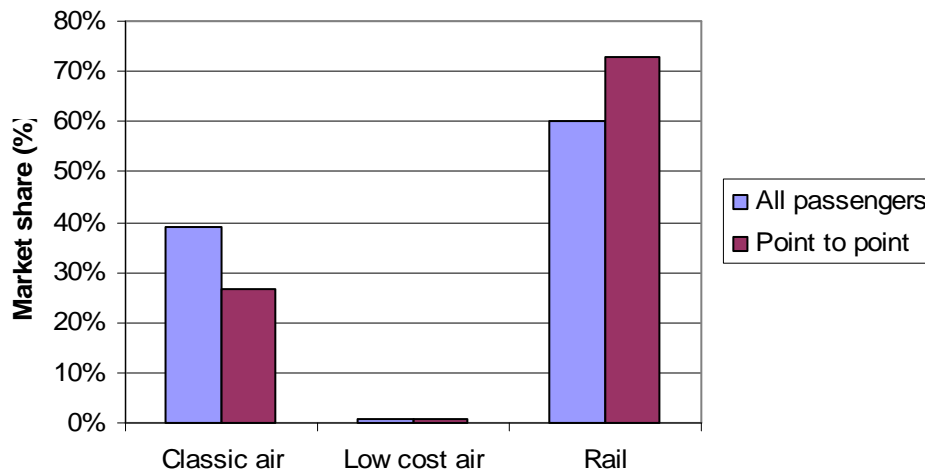

Source: SDG analysis

#### Market share objectives for the rail operator

- 10.23 Representatives of Virgin stated that the key commercial priority for the operator is to capture the high-yield business market. However, apart from passengers making connections to onward flights, and perhaps some travelling to and from the M4 corridor (from which Heathrow is particularly accessible), they do not consider any part of the market to be out of reach.

#### Access to services

- 10.24 Rail services are generally more accessible than air services, especially for passengers travelling between London and Manchester's city centres. However, the fact that London has five airports, all with direct services to Manchester, means that a high proportion of the city's population is within reasonable reach of an air service.
- 10.25 The close proximity of London to Manchester means that passengers travelling from the northern side of London or the southern side of Manchester are less likely to travel by air.

#### London

- 10.26 The London airports' passenger catchment area includes Greater London boroughs, Hertfordshire, Surrey, Berkshire, Essex, Buckinghamshire, Kent, East Sussex, West Sussex, Suffolk, Hampshire, Bedfordshire, Cambridgeshire, Norfolk, and Oxfordshire.
- 10.27 London Heathrow Airport is accessible from the city centre via rail, underground, and bus. Heathrow Express operates a quarter-hourly express rail service between Heathrow Airport and Paddington station in the city centre. In addition to buses, Stansted, and Gatwick airports are connected to London's main rail stations (including King's Cross station) by direct train services. London City airport is located ten

kilometres away from the city's financial district, and is accessible directly via the Docklands Light Railway and shuttle buses.

10.28 Euston station is located in the city centre, and is a hub for commuter rail, underground and bus services.

10.29 Table 9.2 shows public transport and car access times from London's city centre to the terminals. We show the following:

- access times and costs by public transport from city centre to terminal;
- weighted average public transport access times and costs, calculated by weighting access times between the centre of each origin borough to the terminal by borough population. We further assume that only passengers living within greater London area would go to the airports by public transport; and
- weighted average drive times and parking charges.

**TABLE 10.2 ACCESS TIMES AND COSTS TO LONDON TERMINALS**

Terminal	Access by public transport from city centre		Journey time by population distribution (minutes)	Parking fess (24 hours at terminal)
	Journey time (minutes)	Cost		
Heathrow	46	£13: Heathrow Express £4: Underground	66	£43
Gatwick	44	£14: Gatwick Express £9: National Rail	72	£18.5
Luton	65	£11.5: National Rail	76	£25
Stansted	54	£15: Stansted Express	74	£20.5
City	38	£3: Docklands Light Railway	78	£20
Euston Station	n/a	n/a	66	

Source: TfL Journey Planner, BAA website, London City Airport website, Luton Airport website, NCP customer service. *Prices in January 2006*

10.30 According to our analysis, in London, City and Gatwick airports can be most quickly accessed by public transport. Driving times are consistently higher than public transport times for the London terminals, whereas the reverse is true in Manchester, although only marginally so for rail. Rail services are more accessible in general than the airport across the catchment area.

Manchester

10.31 Manchester airport illustrated their catchment area in their Ground Transport Strategy paper in 2004. This consisted of highlighting those counties and unitary administrations in the region contributing more than 250000 passengers per year. These covered the area from north-east Wales in the west over to Kingston upon Hull and north Lincolnshire in the east, and from Staffordshire and Derbyshire in the south

up to North Yorkshire and Cumbria in the north. However, as the catchment area for domestic services will be significantly smaller than for short-haul and long-haul international flights, we restrict our attention to Greater Manchester (excluding northern districts such as Bolton and Rochdale), the northern parts of Cheshire, and Warrington.

- 10.32 Manchester airport is well served by public transport, based at its purpose-built, multi-modal transport interchange, ‘The Station’. During the day there are six trains per hour taking 15-20 minutes to reach the city centre. Some of these continue in other areas of the city, and there are also night services. There are also frequent buses to the city centre, and ‘The Station’ provides direct access to the local bus network.
- 10.33 Manchester Piccadilly station is located on the south-eastern side of the city centre. It is served by the free Metroshuttle city centre bus service, and provides excellent access to the city’s public transport network.
- 10.34 Average access times to Manchester terminals are calculated by weighting access times between representative points in each origin region and the terminal. Where the rail service can be accessed more quickly at an intermediate stop such as Stockport or Macclesfield we have assumed passengers will use these. Average access times are given for both car and public transport in Table 10.3.

**TABLE 10.3 ACCESS TIMES AND COSTS TO MANCHESTER TERMINALS**

Terminal	Access by public transport from city centre		Journey time by public transport by population distribution (minutes)	Access by car (weighted by population)	
	Journey time (minutes)	Cost		Journey time (minutes)	Parking fess (24 hours at terminal)
Manchester Airport	15-20	£2.60: National Rail	44	29	£19
Manchester Piccadilly	n/a	n/a	16	77	£11

Source: TfL journey planner; www.transportdirect.info, NCP website, Manchester airport website. *Prices in January 2006*

Check-in times

- 10.35 Low cost carriers generally require earlier check-ins than classic airlines, thus essentially lengthening total journey time by 30 to 90 minutes. There is no need to check in for rail journeys between London and Manchester.
- 10.36 In addition, the free seating-policy and boarding procedures for low-cost carriers imply that the earlier a passenger checks in, the wider of choice of seats s/he would have on-board. It is possible, however, to pre-book a seat with Air Berlin for an additional €8 charge. Emergency exit row seats (with extra leg-room) can also be pre-booked on Jet2 flights for a charge of €15.
- 10.37 Jet2 recommend that their passengers arrive for check-in no later than 90 minutes prior to the departure time, although desks do not close until 30 minutes before the

flight. Passengers arriving after this point risk being refused carriage. Air Berlin require passengers to arrive at the airport at least 60 minutes in advance.

- 10.38 Classic airlines recommend that UK and Ireland passengers check in one hour prior to departure. On-line check-in services are available to BA passengers on any ticket type (e.g. e-ticket, cardboard ticket, paper ticket). At City airport check-in closes just 15 minutes prior to departure for VLM flights. British Airways and bmi both offer self-service check-in machines at the airports.

#### Air-rail connections

- 10.39 There are no direct rail services either from Manchester to a London airport, or from London to Manchester airport. There is therefore no scope for passengers to connect to flights in either direction having undergone the initial part of their journey by rail. Such connections would require at least one intermediate rail connection, and hence are not viable as a competitive service. Passengers from Manchester catching flights from the main London airport (Heathrow) would find it more convenient either to take a connecting flight or to travel by road.

- 10.40 There are no code-share agreements between Virgin Trains and airlines.

#### Fares and ticketing

##### Level of fares

- 10.41 In order to estimate the average fares that passengers pay, we have compared fares on the London to Manchester route for a large number of potential journey combinations, in order to estimate average fares. Our sample was designed to be representative of the types of journeys passengers typically make, although we cannot be certain that it is exactly right. The average of the sample of fares we collected is shown in Figure 10.7 below. Virgin Trains fares are, on average, lower than any of the other operators.

**FIGURE 10.7 LONDON-MANCHESTER AVERAGE SAMPLED FARES**

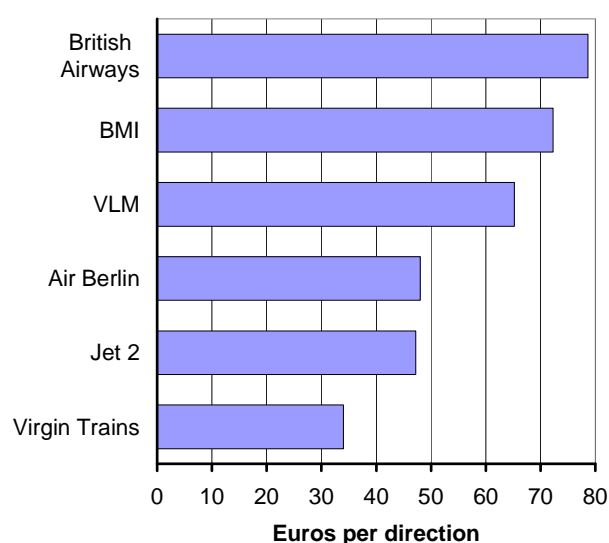

Source: Operators' websites

10.42 All of the operators use yield management systems and so the fares varied significantly depending on advance booking period and time of travel. Some tickets for British Airways and for the rail operator, Virgin Trains, had to be purchased as returns, but even these operators generally had relatively good-value single fares available.

10.43 Figure 10.8 below shows return fares for two specific types of journeys – a day return booked 24 hours in advance (typical of a business passenger) and a weekend return fare booked 2 months in advance (typical of a leisure passenger). Virgin Trains was the cheapest option for the example leisure journey, but was more expensive than the low cost airlines for the business trip. Interestingly, the fare for the leisure trip offered by British Airways was lower than that offered by Air Berlin, one of the low cost carriers.

**FIGURE 10.8 LONDON-MANCHESTER EXAMPLE RETURN FARES**

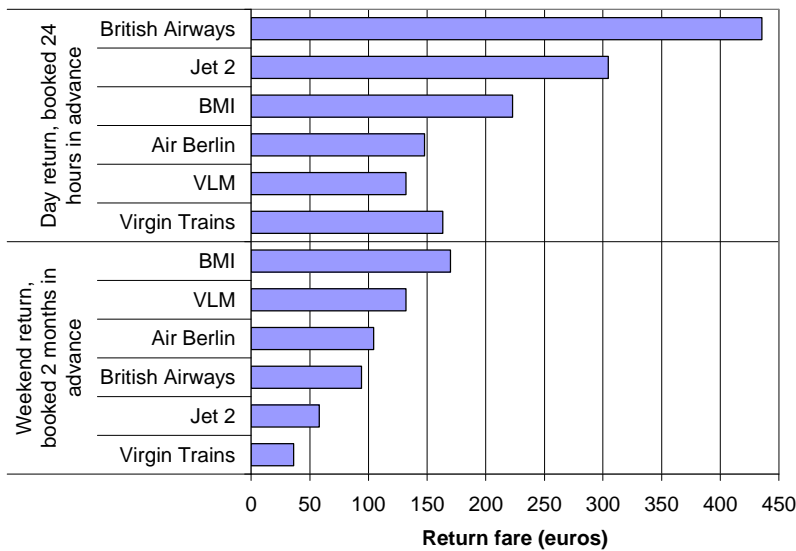

Source: Operators' websites

10.44 The cheapest available tickets for this route are Virgin's Value Advance singles, which start at £12.50 (around €17). However these tickets are only available in very limited numbers and therefore have to be booked well in advance. Furthermore, they are non-refundable and changes can only be made for a £10 charge plus the difference between fares. For first class and flexible travel tickets, Virgin's prices ranged up to nearly £320 (€460) return. The airlines charge similar prices to the rail operator for fully-flexible return tickets, but their entry-level advance purchase fares were generally more expensive than the rail operator.

10.45 Relative to the other airlines, the low cost airlines offer the advantage of all tickets being changeable, albeit subject to a fee. In the course of our research, British Airways announced that it was to change its pricing model to compete better with the low cost carriers. All of its discounted fares will also be changeable in the future.



---

### Trends in fares

- 10.46 According to representatives from Virgin, rail fares are limited by passengers' perception as much, if not more than, price competition from airlines or other competitors. Rail fare increases in the UK are widely reported, much more than increases in air fares. The operator told us that headline prices increased by 7.9 percent in 2005 (RPI+5), although the increase in yields was lower due to changes in mix. This is a result of more passengers buying the cheaper advance purchase fares which are available.
- 10.47 Part of the reason airlines have been able to achieve such significant reductions in their fares in recent years is effective yield management. The difficulty in applying these techniques to the same extent on rail is seen by Virgin as limiting their ability to achieve similar reductions. Season tickets, and in particular walk-up fares (there are few season tickets bought for London-Manchester), make sophisticated yield management difficult because Virgin do not know the times at which people travel.

### Ticketing

- 10.48 All of the rail and air operators sell tickets through their websites. The airlines all offer e-tickets, and Virgin have 'FastTicket' facilities at both London Euston and Manchester Piccadilly allowing passengers to print out their tickets at the station immediately prior to travel.
- 10.49 People have traditionally bought rail tickets from stations, and this is still the case for the majority of passengers. Virgin estimate that at present only 10 percent of their sales are online. They are seeking to encourage more online sales, and the availability of cheap, advance purchase fares via the internet is helping in this. They do not at present have any plans to introduce full e-ticketing however.

### Service quality and on-board services

- 10.50 Contrary to expectations, practise for the airlines is not determined according to type: low-cost airline Air Berlin offer complimentary food and drinks, whereas classic carrier bmi do not. This illustrates how the distinction between low-cost and classic carriers is becoming increasingly blurred.
- 10.51 Access to local public transport services varies from terminal to terminal. The Heathrow Express and Docklands Light Railway give Heathrow and City airports respectively particularly good access; however, Euston occupies a key location on the tube network and with connecting local rail services is therefore the most appealing terminal from this perspective. Euston also offers the best access to local bus services.
- 10.52 Table 3.4 compares the service quality characteristics for the different types of operators.

TABLE 10.4 SERVICE QUALITY AND ON-BOARD SERVICES

	Rail	Classic airlines	Low-cost airlines
<b>On board service quality</b>			
Seat pitch (economy/standard class)	96cm	79-81cm	74-76cm
Catering included (economy/standard class)	×	Light meal/snack/drinks (ex BMI)	Air Berlin: food and drink to suit the time of day Jet2: ×
Check-in baggage limit	N/A 2 items max on train	20-32kg	18-32kg
Pre-assigned seating	✓	✓	✓ (for additional charge)
Magazine available	✓	✓	✓
1st/business class available	✓	× (although VLM markets itself as a business airline)	×
Key differences in 1st/business class	Lounge, larger seating, newspaper, food & drinks	N/A	N/A
Typical price surcharge for 1st/business class	50%	N/A	N/A
<b>Airport / terminal facilities</b>			
Catering facilities	✓	✓	✓
Retail outlets	✓	✓	✓
Heated/secure waiting lounge	×	✓	✓
Toilets	✓ (but charge)	✓ (free)	✓ (free)
Business lounge available	✓	✓	×
Business lounge open to all 1st class passengers	✓	N/A	N/A

### Punctuality and reliability

#### Punctuality

- 10.53 The ‘incumbent’ airline, British Airways, has the worst performance record of amongst the operators. British Airways’ punctuality performance (51%) is significantly worse than that of BMI’s (72%) and VLM’s (71%).
- 10.54 Figure 9.10 shows the punctuality of services between London and Manchester on the different types of carriers. Because Jet2.com only came into operation in September

2004, we could not supply their 2004 performance information. The performance level for low cost carriers refers to Jet2.com's November 2005 performance. It should be noted that the punctuality figure (Public Performance Measure within 10 minutes) for rail covers the entire Virgin West Coast franchise, and is not specific to journeys between London and Manchester.

**FIGURE 10.9 PUNCTUALITY ON LONDON-MANCHESTER ROUTE (2004)**

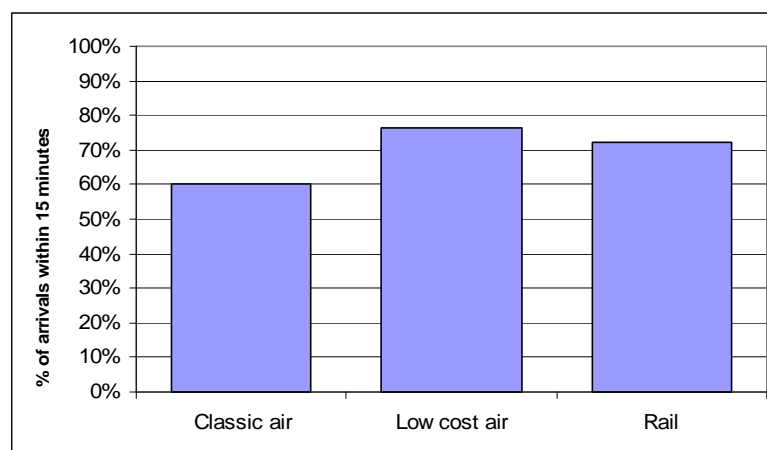

Source: UK CAA, Rail Industry Monitor 2005

#### Reliability

- 10.55 As discussed in the London-Edinburgh case study, a critical problem is that rail services within the UK are prone to severe disruption at weekends due to engineering works. The London-Manchester route has suffered severely from this, as the line used (the West Coast Main Line) has been undergoing a major upgrade in recent years, designed to improve the speed and capacity of the route. This has resulted in major disruptions to passenger services, particularly at weekends, but also at some periods during the week, with parts of the railway closed altogether at certain times. Between 2003 and 2004, an alternative rail service was provided via a different route in order to maintain direct services between London and Manchester, but this had a significantly longer journey time (3 hours 15 minutes).
- 10.56 The West Coast Main Line was also subject to severe disruption after an accident at Hatfield in October 2000, which resulted in substantially extended journey times across the UK rail network for a long period, and a large number of route closures.

#### Taxes, subsidies and regulatory limits

- 10.57 The rail service between London and Manchester is one of the more heavily subsidised long distance rail lines in the UK, because the recent major upgrades of the infrastructure used (the West Coast Main Line) have required substantial investments. The direct subsidy per passenger kilometre on West Coast Main Line (WCML) services increased by 278% between 1996/97 and 2003/04. By 2003/04, Virgin were receiving subsidies of £0.12 (€0.18) per passenger-kilometre. To place this in context with other long-distance services in the UK, Virgin received £0.09 for its Cross Country operation; for InterCity services to the West of England and Wales, the figure

was £0.01 pence, and GNER paid a premium of £0.06 per passenger-kilometre to run its East Coast Mainline services in 2003/04.

- 10.58 The tax and regulatory regime affecting air and rail services within the UK is discussed in more detail within the London-Edinburgh case study.

#### **Future developments**

- 10.59 Weekend engineering work on the WCML are due to end in December 2008, at which point a new timetable will be introduced. This will bring significant improvements to the weekend service, and should further serve to address the rail service's poor reputation on reliability. The operator is also considering operating a London-Manchester service every 20 minutes from this point.
- 10.60 The government has consulted on, as is currently considering, building a toll motorway between Birmingham and Manchester. This could reduce congestion on a very busy stretch of the motorway network, potentially improving car journey times and reliability. This would be viewed by Virgin trains as a threat to their share of the London to Manchester market.
- 10.61 Virgin Trains currently have an Invitation to Tender (ITT) issued for the installation of Wi-Fi wireless internet on their trains. If introduced, this could improve the attractiveness of rail over air on the route particularly in the key business market.

#### **Conclusions**

- 10.62 Despite a relatively short rail journey time, and relatively inconveniently located airports in London, rail only has a share of around 60% of the air/rail market on this route. A key factor is that the line used by London-Manchester rail services has been subject to severe disruption since 2000, due to the Hatfield rail accident and engineering works undertaken by the infrastructure manager, Network Rail. However, rail market share has improved significantly since a new rail timetable was introduced in late 2004 and as punctuality has begun to improve. Trains are now faster, more frequent and reliable than before.
- 10.63 Rail market share should increase further after the completion of the upgrade of the West Coast Main Line. This will allow further improvements in journey time and, perhaps more importantly, improve the reliability of the service. This may prompt some airlines to consider withdrawing services although this will depend on the ticket prices charges by the rail operator.

## CONTROL SHEET

Project/Proposal Name: AIR AND RAIL COMPETITION AND COMPLEMENTARITY

Document Title: Case study report

Client Contract/Project Number:

SDG Project/Proposal Number: 206600

## ISSUE HISTORY

Issue No.	Date	Details
1	28 April 2006	First draft to client
2	4 August 2006	Final revised report

## REVIEW

Originator: Francesco Dionori, Ben Durbin, Erica Chan, Elisa Tejedor, Wolfgang Grimme, Carine Vellay, Simon Smith

Other Contributors:

Review By: Print: Simon Smith

Sign: .....

## DISTRIBUTION

Clients: Vicenc Pedret Cusco, European Commission

Steer Davies Gleave:

